

The background features a stylized globe with a grid of latitude and longitude lines, overlaid with a network of glowing blue and white lines that suggest data flow and connectivity. The overall color palette is dominated by various shades of blue, from light cyan to deep navy.

**net**sys

*Networking your world*

**NV-720S**

**ADSL2+/VDSL2 Wi-Fi**

**USER'S MANUAL**

[Http://www.netsys.com.tw](http://www.netsys.com.tw)

## **Copyright**

Copyright © 2017 by National Enhance Technology Corp. All rights reserved.

### **Trademarks**

NETSYS is a trademark of National Enhance Technology Corp.

Other brand and product names are registered trademarks or trademarks of their respective holders.

### **Legal Disclaimer**

The information given in this document shall in no event be regarded as a guarantee of conditions or characteristics. With respect to any examples or hints given herein, any typical values stated herein and/or any information regarding the application of the device, National Enhance Technology Corp. hereby disclaims any and all warranties and liabilities of any kind, including without limitation warranties of non-infringement of intellectual property rights of any third party.

### **Statement of Conditions**

In the interest of improving internal design, operational function, and/or reliability, NETSYS reserves the right to make changes to the products described in this document without notice. NETSYS does not assume any liability that may occur due to the use or application of the product(s) or circuit layout(s) described herein.

Maximum signal rate derived from IEEE Standard specifications. Actual data throughput will vary. Network conditions and environmental factors, including volume of network traffic, building materials and construction, and network overhead, lower actual data throughput rate. Netsys does not warrant that the hardware will work properly in all environments and applications, and makes no warranty and representation, either implied or expressed, with respect to the quality, performance, merchantability, or fitness for a particular purpose. Make sure you follow in line with the environmental conditions to use this product.

## Foreword: VDSL2 Router solution

### Attention:

**Be sure to read this manual carefully before using this product. Especially Legal Disclaimer, Statement of Conditions and Safety Warnings.**

Netsys' NV-720S is a managed wireless VDSL2 router that leverages the extraordinary bandwidth promise of VDSL2 technology and compliant with the IEEE 802.11b/g/n standard. It can enhance wireless speeds up to 300 Mbps\* and extend the coverage. NV-720S also supports one-touch Wi-Fi Protected Setup (WPS) with the push button that only takes a few seconds to setup a secured wireless network.

In recent years, the market for wireless communications has enjoyed tremendous growth. Wireless technology now reaches or is capable of reaching virtually every location on the surface of the earth. Hundreds of millions of people exchange information every day via wireless communication products. Anyone can bring a built-in WLAN client smart phone, tablet or notebook into a meeting room for a conference without laying a clot of LAN cable or drilling holes everywhere. Wireless LAN enables high mobility so WLAN users can simultaneously access all LAN facilities just like on a wired LAN as well as Internet access. The NV-720S is equipped with a wireless LAN interface compliant with the standard IEEE 802.11b/g/n protocol. To boost its performance even further, the NV-720S is also loaded with an advanced wireless technology to lift up the data rate up to 300 Mbps\*. You can finally smoothly enjoy a wide range of apps on your smart phone, tablet or smart TV.

(\*). The maximum wireless data transfer rate is derived from IEEE Standard 802.11 specifications. Actual data transfer rate will vary from network environment including: distance, network traffic, building site materials/construction, interference from other wireless devices, and other adverse conditions.

### Caution:

The NV-720S is for **indoor** applications only. This product does not have waterproof protection, please do not use in outdoor applications.

## Safety Warnings

For your safety, be sure to read and follow all warning notices and instructions before using the device.

- ◆ **DO NOT** open the device or unit. Opening or removing the cover may expose you to dangerous high voltage points or other risks. ONLY qualified service personnel can service the device. Please contact your vendor for further information.
- ◆ **Use ONLY** the dedicated power supply for your device. Connect the power to the right supply voltage (110V AC used for North America and 230V AC used for Europe. NV-720S supports 12 VDC power input).
- ◆ **Place** connecting cables carefully so that no one will step on them or stumble over them. **DO NOT** allow anything to rest on the power cord and do **NOT** locate the product where anyone can work on the power cord.
- ◆ **DO NOT** install nor use your device during a thunderstorm. There may be a remote risk of electric shock from lightning.
- ◆ **DO NOT** expose your device to dampness, dust or corrosive liquids.
- ◆ **DO NOT** use this product near water, for example, in a wet basement or near a swimming pool.
- ◆ **Connect ONLY** suitable accessories to the device.
- ◆ **Make sure** to connect the cables to the correct ports.
- ◆ **DO NOT** obstruct the device ventilation slots, as insufficient air flow may harm your device.
- ◆ **DO NOT** place items on the device.
- ◆ **DO NOT** use the device for outdoor applications directly, and make sure all the connections are indoors or have waterproof protection place.
- ◆ **Be careful** when unplugging the power, because it may produce sparks.
- ◆ **Keep** the device and all its parts and accessories out of the reach of children.
- ◆ **Clean** the device using a soft and dry cloth rather than liquid or atomizers. Power off the equipment before cleaning it.
- ◆ This product is **recyclable**. Dispose of it properly.

## TABLE OF CONTENTS

COPYRIGHT .....	1
FOREWORD: VDSL2 ROUTER SOLUTION .....	2
<b>SAFETY WARNINGS</b> .....	3
1.1 Check List .....	7
<b>CHAPTER 2. INSTALLING THE ROUTER</b> .....	8
2.1 Hardware Installation.....	8
2.2 Pre-installation Requirements .....	8
2.3 General Rules .....	9
2.4 Connecting the Router .....	10
2.5 Connecting the RJ-11 / RJ-45 Ports .....	11
2.6 VDSL2 Application.....	12
<b>CHAPTER 3. HARDWARE DESCRIPTION</b> .....	16

3.1 Front Panel.....	17
3.2 Front Indicators .....	17
3.3 Rear Panel .....	18
<b>CHAPTER 4. CONFIGURING THE NV-720S VIA WEB BROWSER .....</b>	<b>21</b>
<b>4.1 BASIC Setup .....</b>	<b>22</b>
<b>4.1.1 Login Webpage .....</b>	<b>22</b>
<b>4.2 Status .....</b>	<b>23</b>
<b>4.2.1 WAN .....</b>	<b>24</b>
<b>4.2.2 LAN .....</b>	<b>25</b>
<b>4.2.3 Statistics .....</b>	<b>26</b>
<b>4.3 WAN Setup .....</b>	<b>27</b>
<b>4.3.1 WAN Interface .....</b>	<b>27</b>
<b>4.3.2 TR-069 settings .....</b>	<b>30</b>
<b>4.3.3 xDSL Configuration .....</b>	<b>35</b>
<b>4.4 System .....</b>	<b>37</b>
<b>4.4.1 Update Software .....</b>	<b>37</b>
<b>4.4.2 Restore Default Settings .....</b>	<b>38</b>
<b>4.5 Wireless (Wi-Fi) Setup.....</b>	<b>39</b>

4.5.1 Basic Configuration 2.4GHz.....	39
4.5.2 Security Setting .....	42
4.6 Applications .....	45
4.6.1 IGMP Settings .....	45
4.6.2 USB setup.....	46
4.6.3 FTP Server.....	47
4.6.4 FTP Client.....	48
4.6.5 TFTP Server.....	49
4.7 SNMP Setup .....	50
<b>APPENDIX A:</b> CABLE REQUIREMENTS .....	53
<b>APPENDIX B:</b> PRODUCT SPECIFICATION.....	56
<b>APPENDIX C:</b> ROUTER/BRIDGED MODE SELECT.....	60
<b>APPENDIX D:</b> TROUBLESHOOTING .....	67
<b>APPENDIX E:</b> COMPLIANCE INFORMATION .....	76
<b>CHINESE SJ/T 11364-2014</b> .....	81

## **Chapter 1.** Unpacking Information

### **1.1 Check List**

Thank you for choosing Netsys NV-720S Before installing the router, please verify the contents inside the package.

#### **Package Contents:**

			
<p>1 x Managed VDSL2 CPE router</p>	<p>1 x QR code for user's manual hyperlink.</p>	<p>Accessory Kit : 1 x Ethernet Cable, 1 x Phone wire , 1 x DC12V Power Adapter</p>	

#### **Notes:**

1. Please inform your dealer immediately for any missing or damaged parts. If possible, retain the carton including the original packing materials. Use them to repack the unit in case there is a need to return for repair.
2. If the product has any issue, please contact your local vendor.
3. Do not use sub-standard power supply. Before connecting the power supply to the device, be sure to check compliance with the specifications. The NV-720S uses a DC12V/1A power supply.
4. The power supply included in the package is commercial-grade. Do not use in industrial-grade applications.
5. Please look for the QR code on the bottom of the product, the user can launch the QR code scanning program to scan and download the user's manual electronic format file. Above QR code icon is for reference.



## Chapter 2. Installing the Router

### 2.1 Hardware Installation

This chapter describes how to install the router and establish the network connections. The NV-720S may be installed on any level surface (e.g. a table or shelf). However, please take note of the following minimum site requirements before you begin. **The NV-720S has pre-installed two rubber feet and 2 x 2dBi external Antennas (2.4 GHz).**

### 2.2 Pre-installation Requirements

Before you start the actual hardware installation, make sure you can provide the right operating environment, including power requirements, sufficient physical space, and proximity to other network devices that are to be connected.

Verify the following installation requirements:

- Power requirements: **DC 12 V / 1A**
- The router should be located in a cool dry place, with at least **10cm/4in** of space at the front and back for ventilation.
- Place the router away from direct sunlight, heat sources, or areas with a high amount of electromagnetic interference.
- Check if the network cables and connectors needed for installation are available.
- **Do not install phone lines strapped together with AC power lines, or telephone office line with voice signal.**
- **Avoid installing this device with radio amplifying stations nearby or transformer stations nearby.**
- **Please note that the voice spectrum allowed by the NV-720S external splitter is 0 KHz ~ 120 KHz.**

## **2.3 General Rules**

Before making any connections to the router, please note the following rules:

- **Ethernet Port (RJ-45)**

All network connections to the router Ethernet ports must be made using Category 5 UTP or above for 100 Mbps, Category 3, 4 UTP for 10Mbps.

No more than 100 meters of cabling may be used between the MUX or HUB and an end node.

- **VDSL2 Port (RJ-11)**

All network connections to the RJ-11port must use **24~26** gauge with **twisted pair** phone wiring.

We **do not recommend** the use of the telephone line 28 gauge or above.

The RJ-11 connectors have six positions, two of which are wired. The router uses the center two pins. The pin out assignment for these connectors is presented below.

Please note that the line port is no polarity, therefore user can reverse the two wires of the phone cable when installed.

RJ-11 Pin out Assignments

Pin#	MNEMONIC	FUNCTION
1	NC	Unused
2	NC	Unused
<b>3</b>	<b>DSL</b>	<b>Used</b>
<b>4</b>	<b>DSL</b>	<b>Used</b>
5	NC	Unused
6	NC	Unused

## **2.4 Connecting the Router**

The router has four Ethernet ports which support connection to Ethernet operation. The devices attached to these ports must support auto-negotiation /10Base-T / 100Base-TX unless they will always operate at half duplex. Use any of the Ethernet ports to connect devices such as Monitor systems, Servers, Switches, bridges or routers.

### **Notes:**

1. The (RJ11) Line port is used to connect the telephone that is connected to VDSL2 CO and CPE router (Point-to-point solution).
2. The Slave device (CPE) must be connected to the Master device (CO) through the telephone wire. The Slave cannot be connected to another Slave, and the Master cannot be connected to another Master.

**2.5 Connecting the RJ-11 / RJ-45 Ports**

- ◆ The line port has 1 connector: RJ-11 . It is used to connect with NV-802S (CO) using a single pair phone cable to NV-720S (CPE) bridge side (point to point solution). (Figure 2.1).

**Red Line: Valid**  
**Blake Line: Invalid**

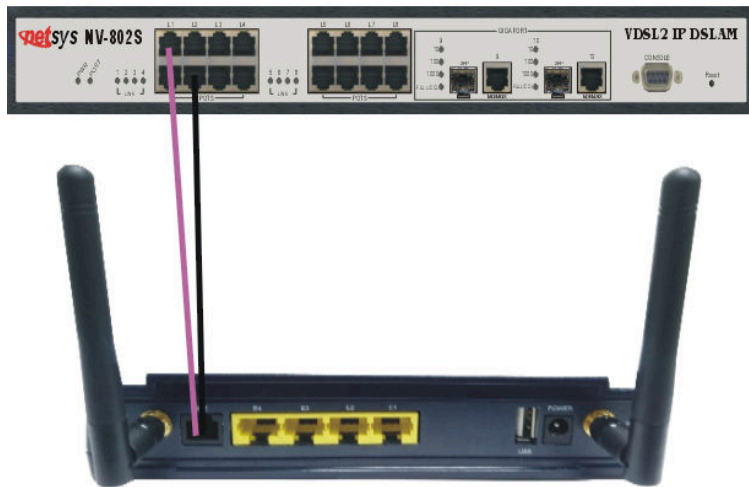

**Figure 2.1 NV-720S line ports straight connection**

- ◆ When inserting a RJ-11 plug, make sure the tab on the plug clicks into position to ensure that it is properly seated.
- ◆ **Do not** plug a RJ-11 phone jack connector into the Ethernet port (RJ-45 port). This may damage the router. Instead, use only twisted-pair cables with RJ-45 connectors that conform to Ethernet standard.

**Notes:**

1. Be sure each twisted-pair cable (RJ-45 Ethernet cable) does not exceed 100 meters (333 feet).
2. We advise using Category 5~7 UTP/STP cables for making Bridge or Router connections to avoid any confusion or inconvenience in the future when you attach high bandwidth devices.
3. Use **24 ~ 26** gauge twisted pair phone wiring, we do not recommend 28 gauge or above.
4. Be sure phone wire has been installed before the NV-720S boot.

**2.6 VDSL2 Application**

The router's line port supports up to 3km for data service across existing phone wiring. It is easy-to-use and do not requires installation of additional wiring. Every modular phone jack in the home can become a port on the LAN. Networking devices can be installed on a single telephone wire that can be installed within a suitable distance. (Figure 2.2)

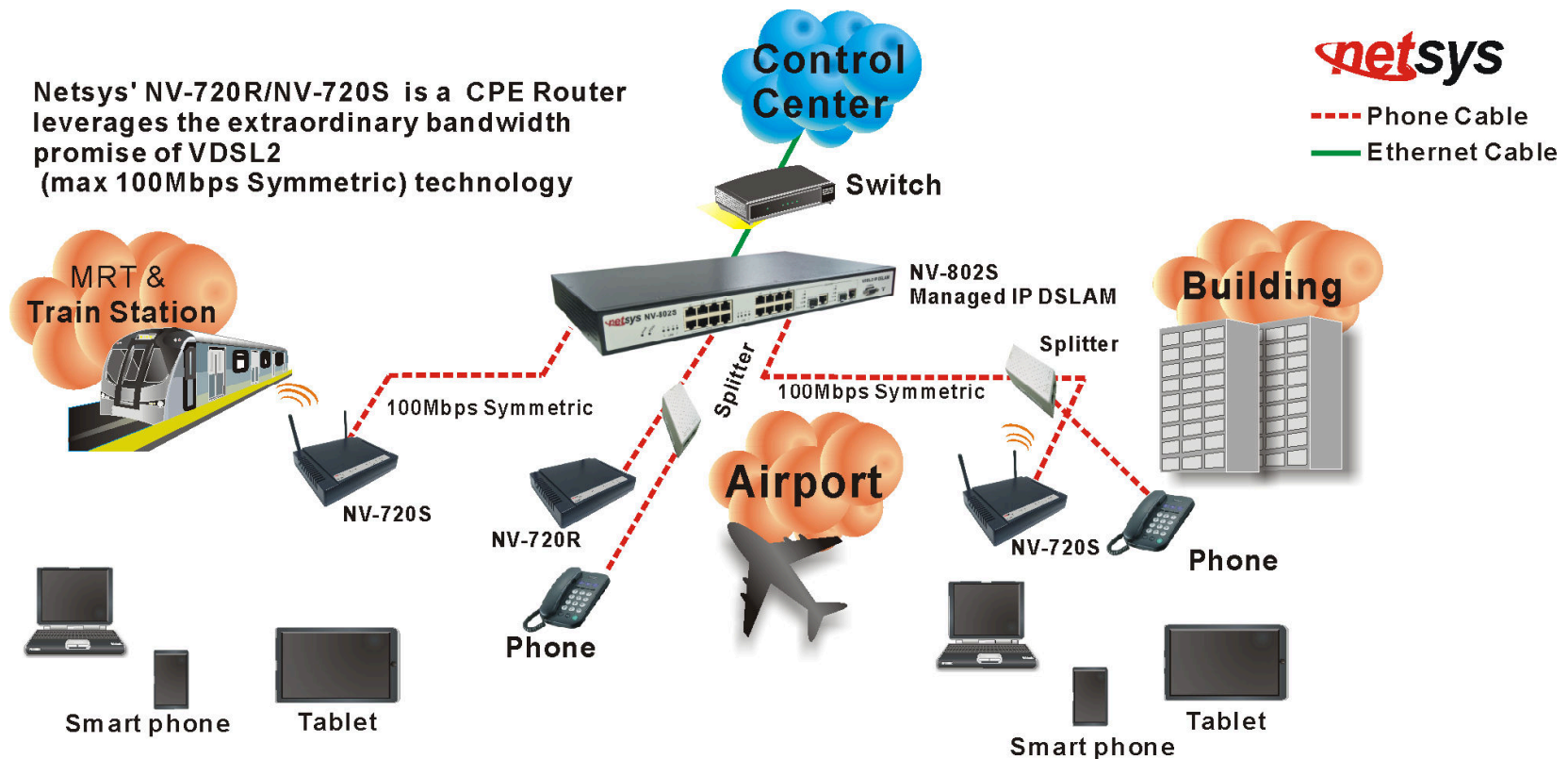

**Figure 2.2 NV-720S applications**

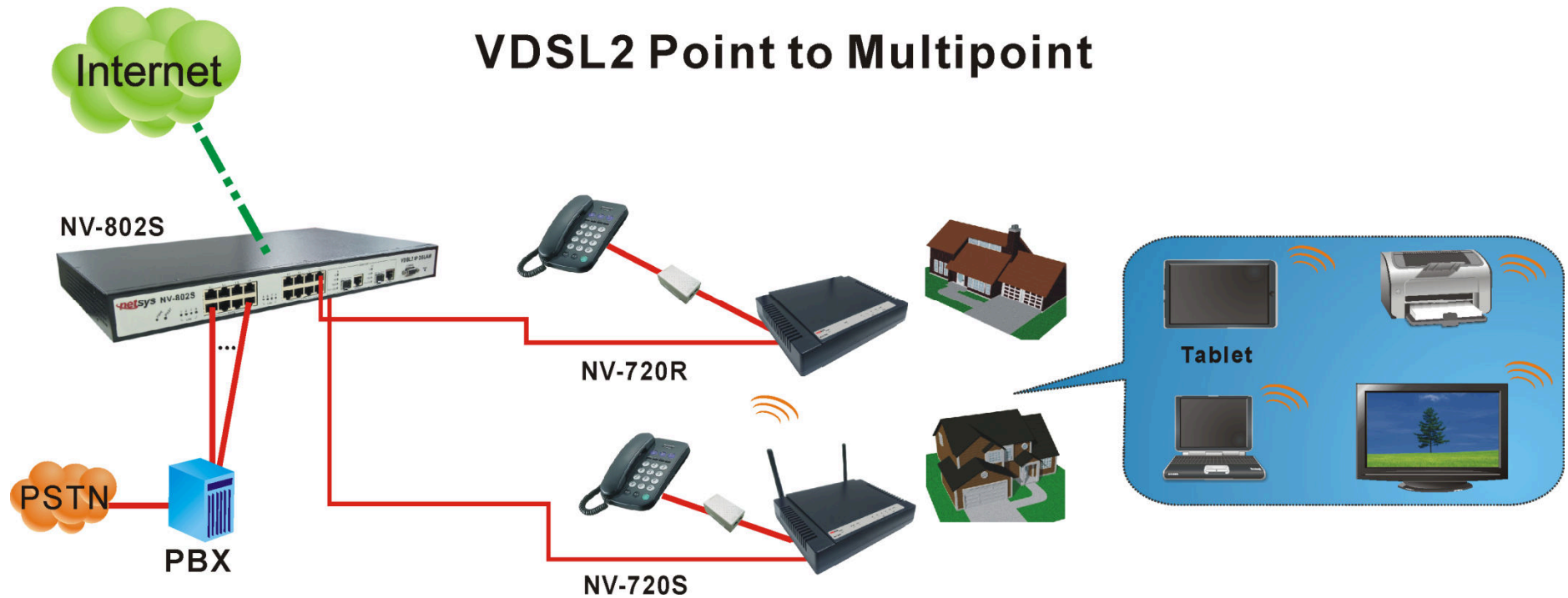

**Figure 2.2.1 VDSL2 applications**

◆ **2.6.1 Connect the NV-802S and the NV-720S to the Line**

The objective for VDSL2 is to pass high speed data over a twisted pair cable. In the setup, connect NV-802S to NV-720S through phone wire (24~26 AWG) or line simulator or any other hardware representation of a cable network, with or without noise injection and crosstalk simulations.

◆ **2.6.2 Connect the NV-802S and the NV-720S to LAN Devices**

In the setup, usually an Ethernet tester serves as a representation of the LAN side as well as a representation of the WAN side.

◆ **2.6.3 Run Demos and Tests**

The Ethernet tester may send data downstream as well as upstream. It also receives the data in order to check the integrity of the data transmission. Different data rates can be tested under different line conditions.

◆ **2.6.4 Wireless Basics**

In recent years, the market for wireless communications has enjoyed tremendous growth. Wireless technology now reaches or is capable of reaching virtually every location on the surface of the earth. Hundreds of millions of people exchange information every day via wireless communication products. Anyone can bring a built-in WLAN client Smartphone, tablet or notebook into a meeting room for a conference without laying a clot of LAN cable or drilling holes everywhere. Wireless LAN enables high mobility so WLAN users can simultaneously access all LAN facilities just like on a wired LAN as well as Internet access. The NV-720S is equipped with a wireless LAN interface compliant with the standard IEEE 802.11 protocol. To boost its performance even further, the NV-720S is also loaded with an advanced wireless technology to lift up the data rate up to 300 Mbps. You can finally smoothly enjoy a wide range of apps on your smart phone, tablet or smart TV.

■ **What is WEP?**

Wired Equivalent Privacy (WEP) is an easily broken security algorithm for IEEE 802.11 wireless networks. Introduced as part of the original 802.11 standard ratified in September 1999, its intention was to provide data confidentiality comparable to that of a traditional wired network. WEP, recognizable by the key of 10 or 26 hexadecimal digits, was at one time widely in use and was often the first security choice presented to users by router configuration tools.

■ **What is WPA?**

Wi-Fi Protected Access (WPA) and Wi-Fi Protected Access II (WPA2) are two security protocols and security certification programs developed by the Wi-Fi Alliance to secure wireless computer networks. The Alliance defined these in response to serious weaknesses researchers had found in the previous system, WEP (Wired Equivalent Privacy).

WPA (sometimes referred to as the draft IEEE 802.11i standard) became available in 2003. The Wi-Fi Alliance intended it as an intermediate measure in anticipation of the availability of the more secure and complex WPA2. WPA2 became available in 2004 and is common shorthand for the full IEEE 802.11i (or IEEE 802.11i-2004) standard.

A flaw in a feature added to Wi-Fi, called Wi-Fi Protected Setup, allows WPA and WPA2 security to be bypassed and effectively broken in many situations. WPA and WPA2 security implemented without using the Wi-Fi Protected Setup feature are unaffected by the security vulnerability.



## Chapter 3. Hardware Description

This section describes the important parts of the wireless VDSL2 router. It features the front and rear panel.



**Wireless Router Outward**

### **3.1 Front Panel**

The front panel provides a simple interface monitoring of the router. (Figure 3.1) shows the front panel of the NV-720S

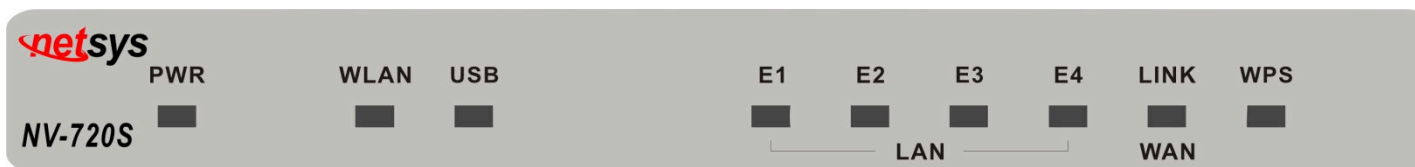

**Figure 3.1 NV-720S Front Panel**

### **3.2 Front Indicators**

The wireless router has **Nine** LED indicators. The following Table shows the description. (Table 3-1)

**Table 3-1 LED Indicators Description and Operation**

LED	Color	Status	Descriptions
PWR (Power LED)	Green	On(Steady)	When the router is powered on, and in ready state.
		Off	When the router is powered off
WLAN (Wireless LED)	Green	On(Steady)	Wireless access point is ready.
		Blinking	Data is being transmitted through WLAN
		Off	Wireless access point is off or has malfunctioned.
USB	Green	On(Steady)	The device has a good USB connection
		Off	The device is not ready or has malfunctioned
LED	Color	Status	Descriptions

E1 ~ E4 (Ethernet LED)	Green	On(Steady)	The device has a good Ethernet connection.
		Blinking	The device is sending or receiving data via the corresponding LAN port.
		Off	The LAN is not connected or has malfunctioned.
LINK (VDSL2 LED)	Green	On(Steady)	The Internet or network connection is up.
		Fast Blinking	The device is sending or receiving data.
		Off	The Internet or network connection is down.
WPS	Green	On(Steady)	The WPS connection is ready.
		Off	The WPS is not available, or WPS is not enabled or initialized

**Notes:**

1. It is normal for the connection between two Routers to take up to 3 minutes, due to NV-802S/NV-720S to establish a link mechanism in auto-negotiation, that detects and calculates CO and CPE both PBO and PSD level, noise levels and other arguments for getting a better connection.
2. Every time the user presses the WPS button, there will be two minutes of time to detect the available equipment. If the WPS function does not detect the device, the WPS light will turn off.

**3.3 Rear Panel**

The rear panel provides the physical connectors connected to the power adapter and any other network device. (Figure 3.2) shows the rear panel of the NV-720S.



**Figure 3.2 Rear Panel**

And the table shows the description. (Table 3-2)

**Table 3-2** Description of the router rear connectors

Connectors	Type	Description
Reset	Reset Button	The reset button allows users to reboot the VDSL2 or load the default settings. <b>Press and hold for 1-5 seconds: Reboot the VDSL2 Router</b> <b>Press over 5 seconds: Load the default settings</b>
Power	DC Power Jack	External Power Adapter: Input: AC 100~240Volts/50~60Hz Output: DC 12V/1A
Line	RJ-11	For connecting to a VDSL2 device.
USB	USB2.0 Type A	For connecting to the USB dongle.
Ethernet (E1-E4)	RJ-45	For connecting an Ethernet equipped device.
WPS WLAN ON/OFF	WPS Button	Press this button over 5 seconds to make a network connection through WPS (WPS function is only supported on windows 7 or above operating systems). Press this button 1~5 seconds to make switch on/off the WLAN. Every time the user presses the WPS button, there will be two minutes of time to detect the available equipment.

**Before installing power and device, please read and follow these essentials:**

- ◆ Use separate paths to route wiring for power and devices. If power and device wiring paths must cross, make sure the wires are

perpendicular at the intersection point.

**Note:**

Do not run signal or communications wiring and power wiring through the same wire conduit. To avoid interference, wires with different signal characteristics should be routed separately.

- ◆ You can use the type of signal transmitted through a wire to determine which wires should be kept separate. The rule of thumb is that wiring sharing similar electrical characteristics can be bundled together.
- ◆ You should separate input wiring from output wiring.
- ◆ We recommend that you mark all equipment in the wiring system.
- ◆ The maximum wireless data transfer rate is derived from IEEE Standard 802.11b/g/n specifications. Actual data transfer rate will vary from network environment including: distance, network traffic, building site materials/construction, interference from other wireless devices, and other adverse conditions.

## **Chapter 4. Configuring the NV-720S via Web Browser**

The NV-720S provides a built-in HTML based management interface that allows configuration of the NV-720S via Internet Browser. Best viewed using Chrome or Firefox browsers.

In order to use the web browser to configure the device, you may need to allow:

- Web browser pop-up windows from your device. Web pop-up blocking is enabled by default in windows XP SP2 or above.
- Java Scripts. (Enabled by default)
- Java permissions. (Enabled by default)

Launch your web browser and input the IP address 192.168.1.1 (NV-720S) in the Web page.  
Following section user can find default username and password.

## **4.1 BASIC Setup**

### **4.1.1 Login Webpage**

The IP address is **192.168.1.1** , username and password are **“admin”**.

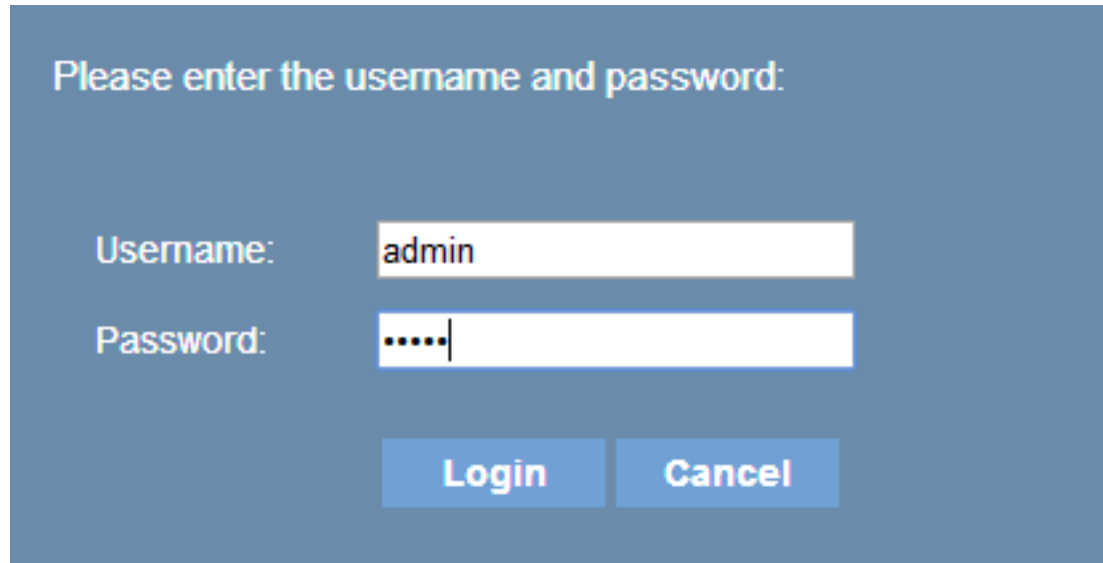

Please enter the username and password:

Username:

Password:

**Figure 4.1 Login Password**

## **4.2 Status**

When the device is running, the status page will display device information for Hardware/Software Version, MAC Address, and System Up Time. A screen is displayed as shown in Figure 4.2.





## Device Info

Hardware Version:	A.3
Software Version:	B.3.2
MAC Address:	00:05:6e:02:03:06
System Up Time:	0 hours, 52 mins, 27 secs

**Figure 4.2 Device Info**

### 4.2.1 WAN

Select “WAN”, and click on “Network” link in the left navigation bar to check IPv4/IPv6 WAN Connection Status. A screen is displayed as shown in Figure 4.2.1.

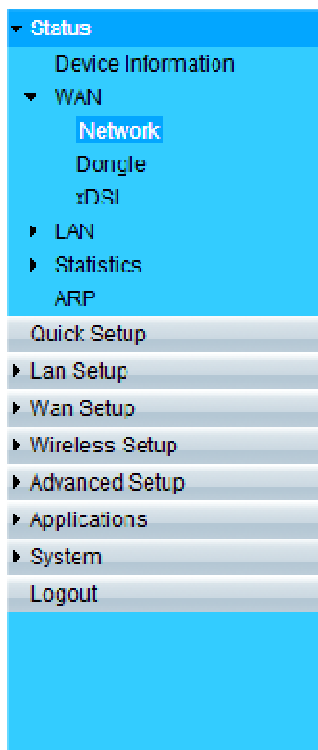

### IPv4 WAN Connection Status

Connection Name	Type	IP Address/Mask	Default Gateway	Primary DNS	Secondary DNS	Status
vdsl	DHCP	192.168.16.54/255.255.255.0	192.168.16.1	192.168.16.1		Connected

### IPv6 WAN Connection Status

Connection Name	Type	IP Address	Default Gateway	Primary DNS	Secondary DNS	Prefix	Status
No Rule Found!							

### DS-Lite Status

Connection Name	Type	Mode	AFTR Address	Status
No Rule Found!				

[Refresh](#)

**Figure 4.2.1 WAN Connection Status**

## 4.2.2 LAN

To check NV-720S Wi-Fi status, click on the “WLAN” link in the left navigation bar. A screen is displayed as shown in Figure 4.2.2.

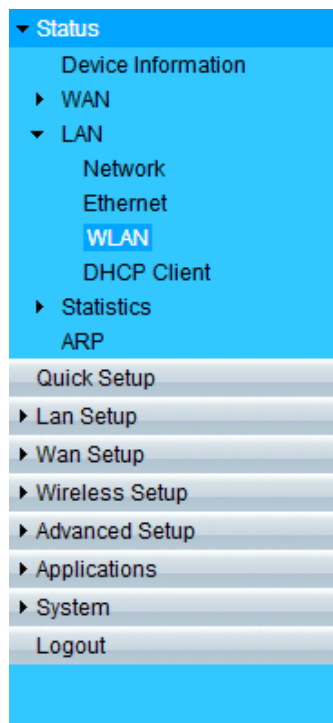

### LAN - WLAN

SSID Index	SSID	BSSID	Status	Authentication Mode	Encryption Mode
SSID-1	dsl_2GAp	00:05:6E:02:03:07	Enable	WPA-PSK/WPA2-PSK	AESEncryption
SSID-2	dsl_2GAp_2	02:05:6E:12:03:07	Disable	WPA-PSK/WPA2-PSK	AESEncryption
SSID-3	dsl_2GAp_3	02:05:6E:22:03:07	Disable	WPA-PSK/WPA2-PSK	AESEncryption
SSID-4	dsl_2GAp_4	02:05:6E:32:03:07	Disable	WPA-PSK/WPA2-PSK	AESEncryption

### Attached Devices Info

IP Address	MAC Address
No Rule Found!	

Refresh

**Figure 4.2.2 WLAN**

## 4.2.3 Statistics

To check xDSL link status, click on the “xDSL” link in the left navigation bar. A screen is displayed as shown in Figure 4.2.3.



**Statistics -- xDSL**

Status:	Up
Line Standard:	G.993.2 /Annex_A
Current Rate(Up/Down):	102409/102393 Kbps
Max Rate(Up/Down):	118571/177816 Kbps
Noise Margin(Up/Down):	8.2/15.7 dB
InterleaveDepth(Up/Down):	19/1
Line Attenuation(Up/Down):	0.8/6.7 dB
Output Power(Up/Down):	8.2/14.2 dBm
FEC(Up/Down):	0/9810
HEC(Up/Down):	0/0
CRC(Up/Down):	0/25804
ESTI.DISTANCE:	123m

Refresh

**Figure 4.2.3 xDSL Link Status**

## 4.3 WAN Setup

### 4.3.1 WAN Interface

### 4.3.1.1 Create ATM Mode

Select “WAN Interface” and click on “ATM” link in the left navigation bar and press “Create”.

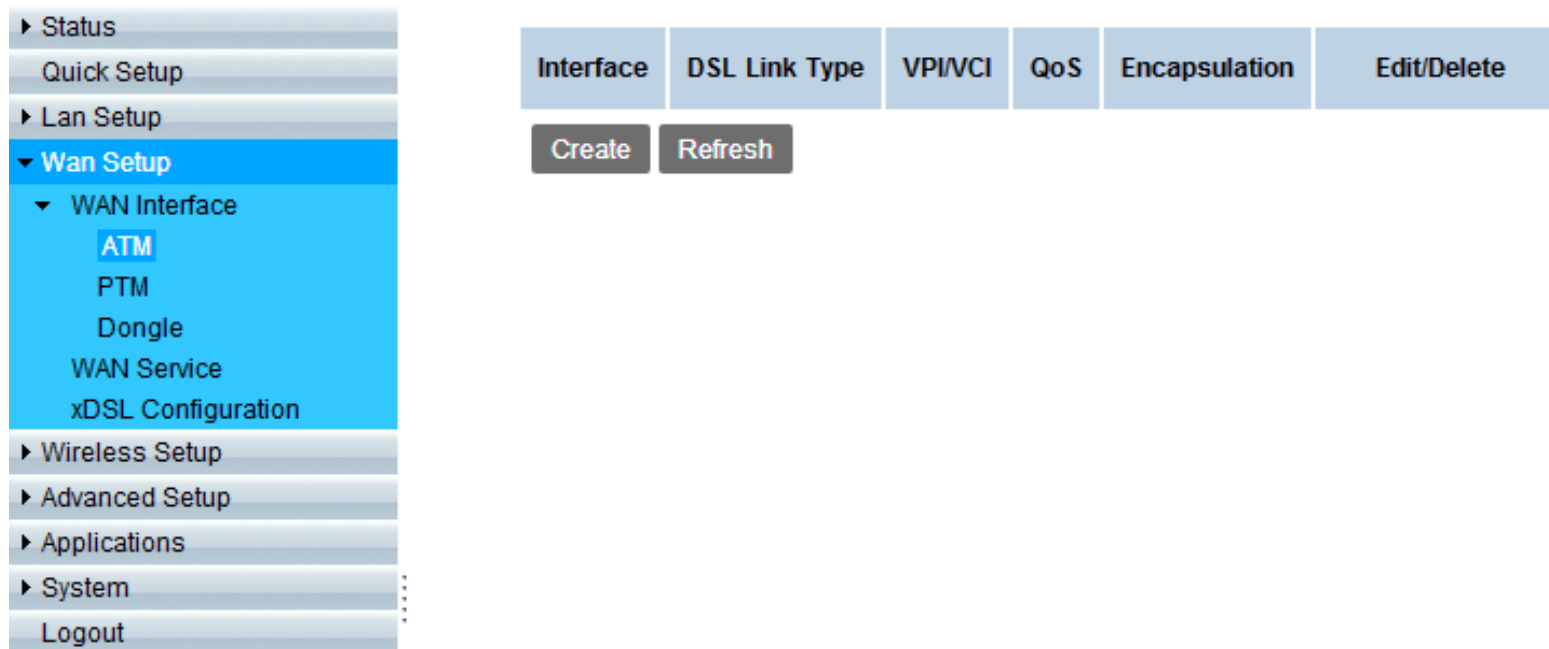

**Figure 4.3.1.1 Create ATM Mode**

### 4.3.1.2 Select ATM Settings

After pressing “Create”, select DSL Link Type, VPI/VCI settings, Encapsulation, and QoS, and press “Apply”, the ATM mode will be successfully created.

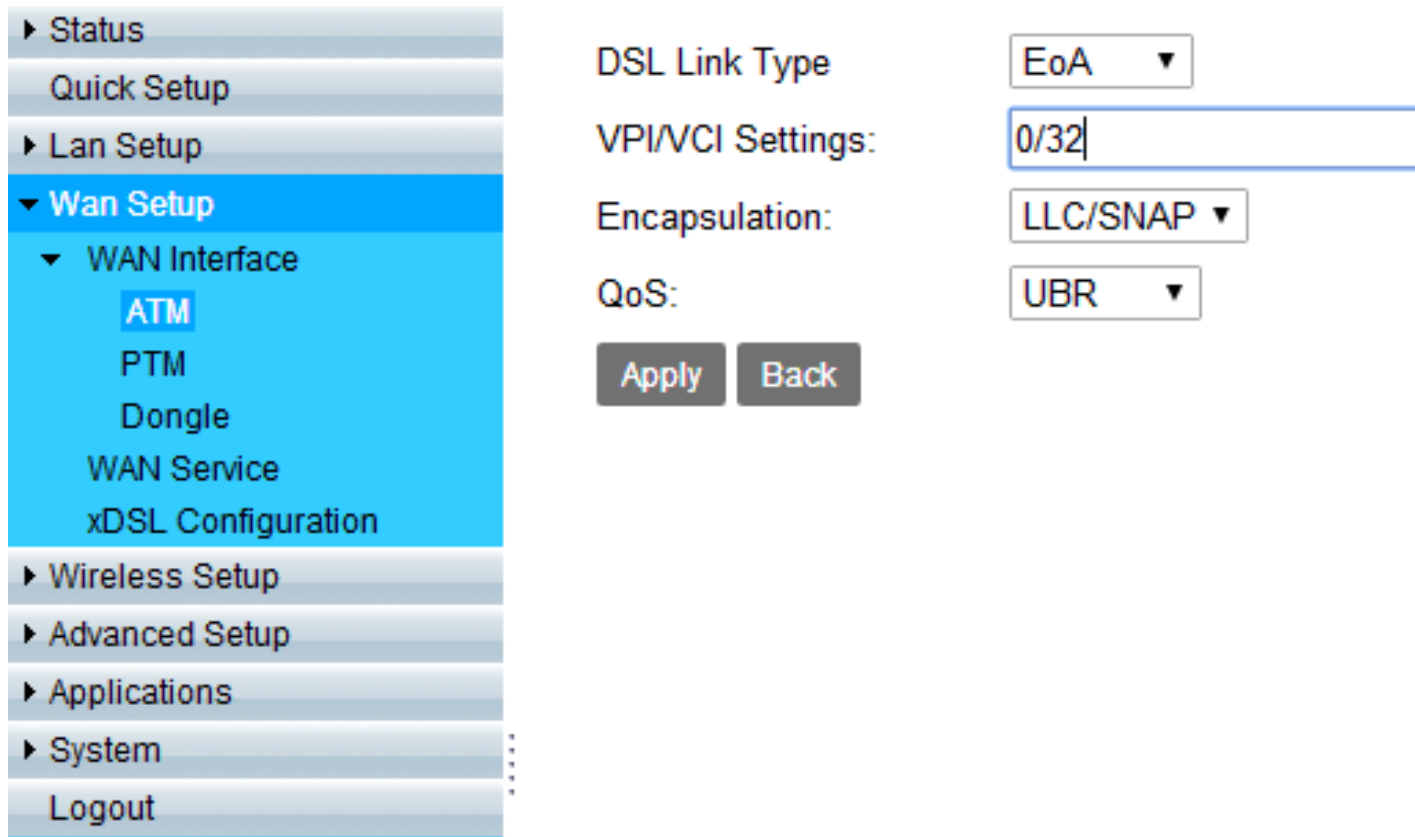

**Figure 4.3.1.2 Select ATM Settings**

### 4.3.1.3 ATM Mode Created

After the ATM mode has been created, there will be three interfaces: ATM/PTM/USB in WAN service.

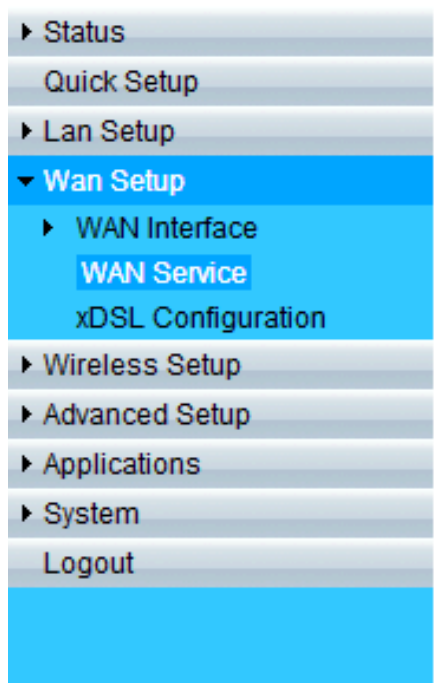

## WAN ServiceInfo

WAN Name	Interface	Mode	IP Protocol Type	Service Type	Edit/Delete
----------	-----------	------	------------------	--------------	-------------

## Set New WAN

Interface:

Mode:

**Figure 4.3.1.3 ATM Mode Created**

## 4.3.2 TR-069 settings

### 4.3.2.1 Set New WAN for TR-069

Select “WAN Service” in the left navigation bar to set new WAN, there will be three interfaces now

(ATM/PTM/USB). To create PTM +PPPoE WAN Router Connection for TR-069, choose PTM interface & PPPoE mode, and press “Create”.

The screenshot shows the 'WAN ServiceInfo' table and the 'Set New WAN' configuration form. The table lists a WAN service named 'vdsI\_PPPoE' using the 'PTM' interface in 'PPPoE' mode with 'IPv4' protocol and 'TR069\_INTERNET' service type. The configuration form shows 'Interface' set to 'PTM' and 'Mode' set to 'DHCP' (with a dropdown menu open showing other options like Static, PPPoE, and Bridge). 'Create' and 'Re' buttons are visible at the bottom of the form.

WAN Name	Interface	Mode	IP Protocol Type	Service Type	Edit/Delete	
vdsI_PPPoE	PTM	PPPoE	IPv4	TR069_INTERNET	Edit	Delete

**Set New WAN**

Interface:

Mode:  (Dropdown menu open showing: DHCP, Static, PPPoE, Bridge)

**Figure 4.3.2.1 Set New WAN**

#### 4.3.2.2 Setup TR-069 WAN Service Type

Type in the connection name and MTU, choose TR069\_Internet for Service Type, and press “Apply”, this WAN Connection can suffer internet and can use TR069.



<ul style="list-style-type: none"> <li>▸ Status</li> <li>▸ Quick Setup</li> <li>▸ Lan Setup</li> <li>▾ Wan Setup             <ul style="list-style-type: none"> <li>▸ WAN Interface</li> <li>▸ WAN Service</li> <li>▸ xDSL Configuration</li> </ul> </li> <li>▸ Wireless Setup</li> <li>▸ Advanced Setup</li> <li>▸ Applications</li> <li>▸ System</li> <li>Logout</li> </ul>	<h3>WAN Service</h3> <p>Connection Name: <input type="text" value="vdsi"/></p> <p>Enable: <input type="checkbox"/></p> <p>MTU: <input type="text" value="576~1492"/></p> <p>IP Protocol Type: <input type="text" value="IPv4"/></p> <p>NAT: <input checked="" type="checkbox"/></p> <p>IPv4 Static DNS: <input type="checkbox"/></p> <p>PPPoE Type: <input type="text" value="Normal PPPoE"/></p> <p>Servicename: <input type="text"/></p> <p>User Name: <input type="text"/></p> <p>Password: <input type="text" value="*****"/></p> <p>Authentication Type: <input type="text" value="AUTO"/></p> <p>Dial Mode: <input type="text" value="Automatically"/></p> <p>Keep Alive Time: <input type="text" value="30"/> (10-30)s</p> <p>Keep Alive Max Fail: <input type="text" value="5"/> (1-100)</p> <p>MAC Address Override: <input type="checkbox"/></p> <p>Enable VLAN: <input type="checkbox"/></p> <p>Service Type: <input type="text" value="TR069_INTERNET"/></p> <p><a href="#">Advanced Settings</a></p> <p><input type="button" value="Apply"/> <input type="button" value="Back"/> <input type="button" value="Refresh"/></p>
---	--

**Figure 4.3.2.2 Setup TR-069 WAN Service Type**

### 4.3.2.3 CWMP

Select “System”, and click on “CWMP” link in the left navigation bar to create TR-069 connection, and setup ACS URL/ ACS User Name/ACS Password and basic information.

**TR069 Settings**

Enable TR069:

ACS URL:

ACS User Name:

ACS Password:

Period Inform:

Inform Interval:

Connection Request Authentication:

User Name:

Password:

Connection Request Port:

Connection Request URL:

**Figure 4.3.2.3 TR-069 Settings**

**Warning:** The settings will restore the factory defaults except WAN connection and TR069 Settings.

Confirm WAN service type must be TR-069 or TR069\_INTERNET.



Service Type:

TR069\_INTERNET ▼

### 4.3.3 xDSL Configuration

Select “xDSL Configuration” in the left navigation bar, choose the Link types, Annex versions, and band profiles.

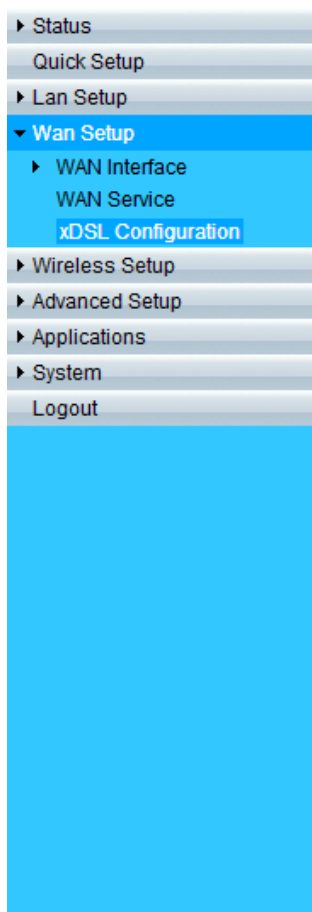

#### WAN - xDSL Configuration

G.DMT	
G.992.1_Annex_A:	<input checked="" type="checkbox"/>
G.992.1_Annex_B:	<input type="checkbox"/>
G-lite	
G.992.2:	<input type="checkbox"/>
T.413	
T1.413:	<input checked="" type="checkbox"/>
ADSL2	
G.992.3_Annex_A:	<input checked="" type="checkbox"/>
G.992.3_Annex_B:	<input type="checkbox"/>
G.992.3_Annex_J:	<input type="checkbox"/>
G.992.3_Annex_L1:	<input checked="" type="checkbox"/>
G.992.3_Annex_L2:	<input checked="" type="checkbox"/>
G.992.3_Annex_M:	<input checked="" type="checkbox"/>

- ▶ Status
- Quick Setup
- ▶ Lan Setup
- ▼ Wan Setup
  - ▶ WAN Interface
  - WAN Service
  - xDSL Configuration
- ▶ Wireless Setup
- ▶ Advanced Setup
- ▶ Applications
- ▶ System
- Logout

ADSL2+	
G.992.5_Annex_A:	<input checked="" type="checkbox"/>
G.992.5_Annex_B:	<input type="checkbox"/>
G.992.5_Annex_J:	<input type="checkbox"/>
G.992.5_Annex_M:	<input checked="" type="checkbox"/>

VDSL2	
G.993.2_Annex_A:	<input checked="" type="checkbox"/>
G.993.2_Annex_B:	<input checked="" type="checkbox"/>
G.993.2_Annex_C:	<input checked="" type="checkbox"/>
Profile:	<input checked="" type="checkbox"/> 8a <input checked="" type="checkbox"/> 8b <input checked="" type="checkbox"/> 8c <input checked="" type="checkbox"/> 8d <input checked="" type="checkbox"/> 12a <input checked="" type="checkbox"/> 12b <input checked="" type="checkbox"/> 17a <input checked="" type="checkbox"/> 30a

Capability	
Enable Bitswap:	<input checked="" type="checkbox"/>
Enable SRA:	<input checked="" type="checkbox"/>
Enable US0:	<input checked="" type="checkbox"/>

Apply
Refresh

**Figure 4.3.3 xDSL Configuration**

## 4.4 System

### 4.4.1 Update Software

To update software, click on the “Update Software” link in the left navigation bar, and follow the steps for updating. A screen is displayed as shown in Figure 4.4.1.

**Update Software**

Step 1: Obtain an updated software image file from your ISP.  
Step 2: Enter the path to the image file location in the box below or click the 'Browse' button to locate the image file.  
Step 3: Click the 'Update Software' button once to upload the new image file.

**Note:** The update process takes about 2 minutes to complete, and your Broadband Router will reboot.

Software File Name:  File not found

**Figure 4.4.1 Update Software**

### 4.4.2 Restore Default Settings

To restore broadband router settings to the factory default, select “Logs”, and click on the “Restore Default” link in the left navigation bar. When click “Restore Default Settings”, the device will reboot in 10 seconds. A screen is displayed as shown in Figure 4.4.2.

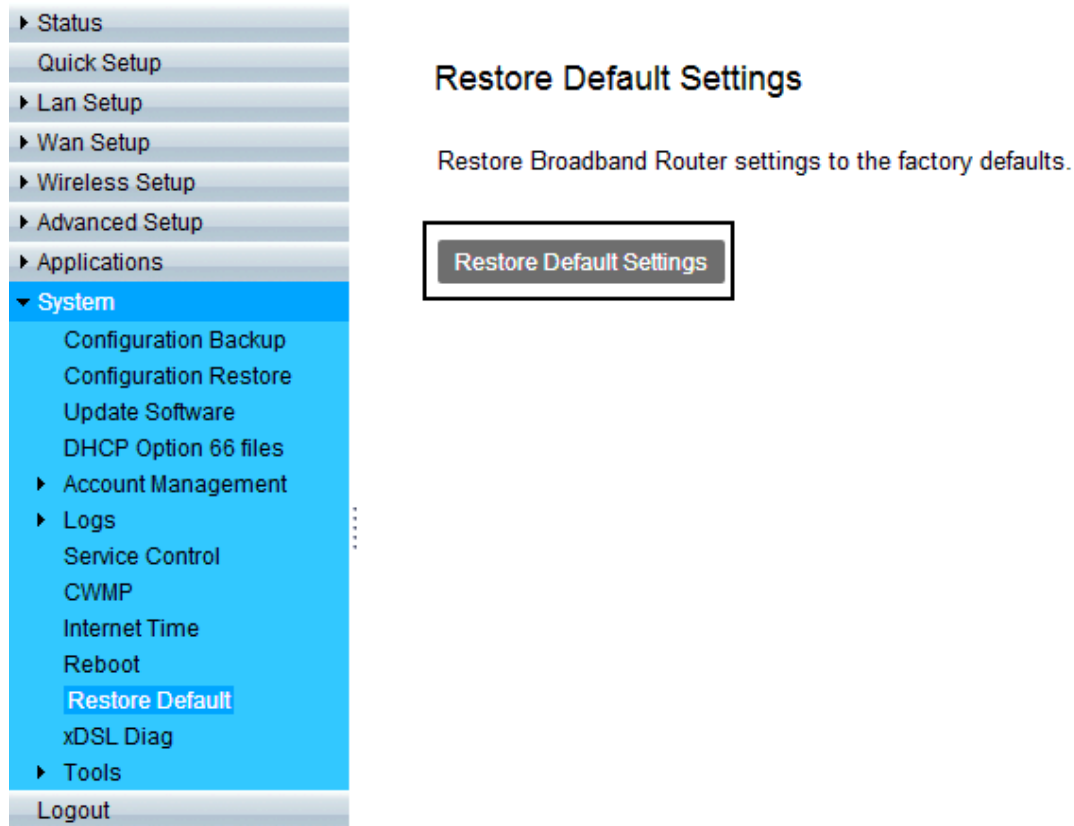

**Figure 4.4.2 Restore Default Settings**

## 4.5 Wireless (Wi-Fi) Setup

### 4.5.1 Basic Configuration 2.4GHz

Select “Basic Configuration 2.4GHz” link in the left navigation bar, and you’ll see the options on the right page. Enable SSID and choose SSID1 to SSID4 for 2.4GHz. Make sure Enable Wireless has been ticked, then you can set your SSID name.

**Wireless Basic Configuration 2.4GHz**

Enable Wireless:

Choose SSID: SSID1 ▾  
SSID1  
SSID2  
SSID3  
SSID4

Enable SSID:

Enable Isolation:

Hide SSID:

SSID:

Maximum Clients:

BSSID:

You can set SSID name in this label

**Figure 4.5.1 Basic Configuration 2.4GHz**



### **4.5.1.1 Advanced Configuration 2.4GHz**

Click on “Advanced Configuration 2.4GHz” link in the left navigation bar, and you’ll see the options on the right page, some options need to be carefully select. First, choose 802.11 b/g/n modes, and set Bandwidth 20/40 MHz.

In the Short GI (Guard Interval) option, the Wi-Fi link rates are different between enable or disable. If enable GI (Guard Interval), the Wi-Fi link rate speed will be the highest, however, the rate speed may depend on the environment.

After pressing “Apply” to setup your options, test Wi-Fi to check your settings are all correct.

Wireless Advanced Configuration 2.4GHz

Mode: 802.11b/g/n ▼

Bandwidth: 40 ▼ MHz

Rate: Auto ▼

TX Power: 100% ▼

Choose Country: TW ▼

Channel: Auto ▼

Current Channel: 9

Beacon Interval: 100

RTS Threshold: 2347

Fragment Threshold: 2346

DTIM Interval: 1

Short GI(Guard Interval):

WMM:

WMM APSD:

Apply Refresh

**Figure 4.5.1.1 Advanced Configuration 2.4GHz Options**

## 4.5.2 Security Setting

Select "Security Setting" link in the left navigation bar, you can change security type in the right page.

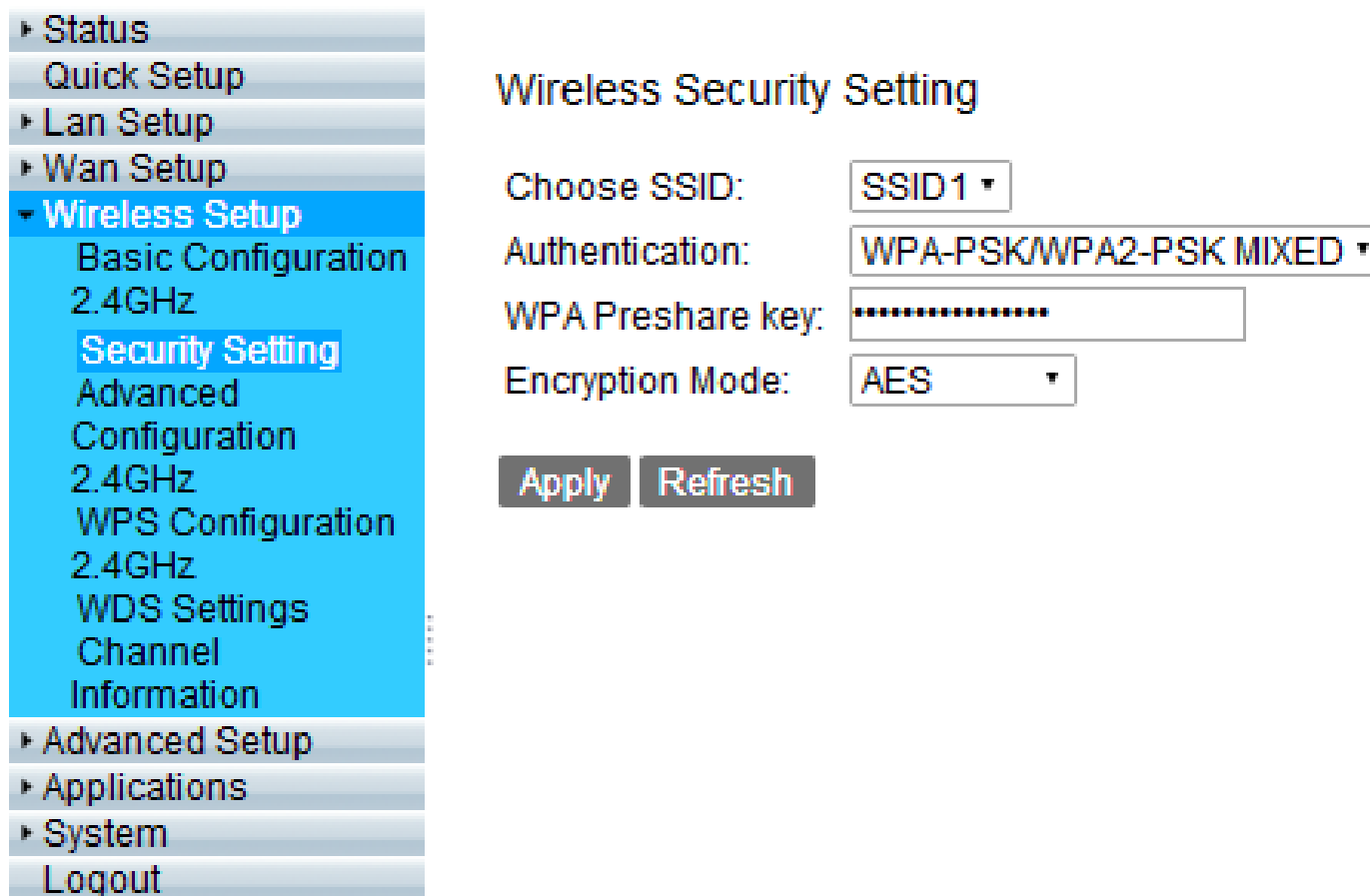

The screenshot displays the 'Wireless Security Setting' configuration interface. On the left, a navigation menu is visible with the following items: Status, Quick Setup, Lan Setup, Wan Setup, **Wireless Setup** (expanded), Basic Configuration 2.4GHz, **Security Setting** (selected), Advanced Configuration 2.4GHz, WPS Configuration 2.4GHz, WDS Settings, Channel Information, Advanced Setup, Applications, System, and Logout. The main content area is titled 'Wireless Security Setting' and contains the following configuration options:

- Choose SSID:
- Authentication:
- WPA Preshare key:
- Encryption Mode:

At the bottom of the configuration area, there are two buttons: **Apply** and **Refresh**.

**Figure 4.5.2 Wireless Security Setting**

### 4.5.2.1 Choose SSID

Please note that SSID1 to SSID4 are 2.4GHz Wi-Fi settings and confirm the SSID number here should be matched with Basic Configuration page above.



**Figure 4.5.2.1 Choose SSID**

### 4.5.2.2 Authentication Options

In Authentication options, you can change security type. Normally, test Wi-Fi to check your security type are correct.

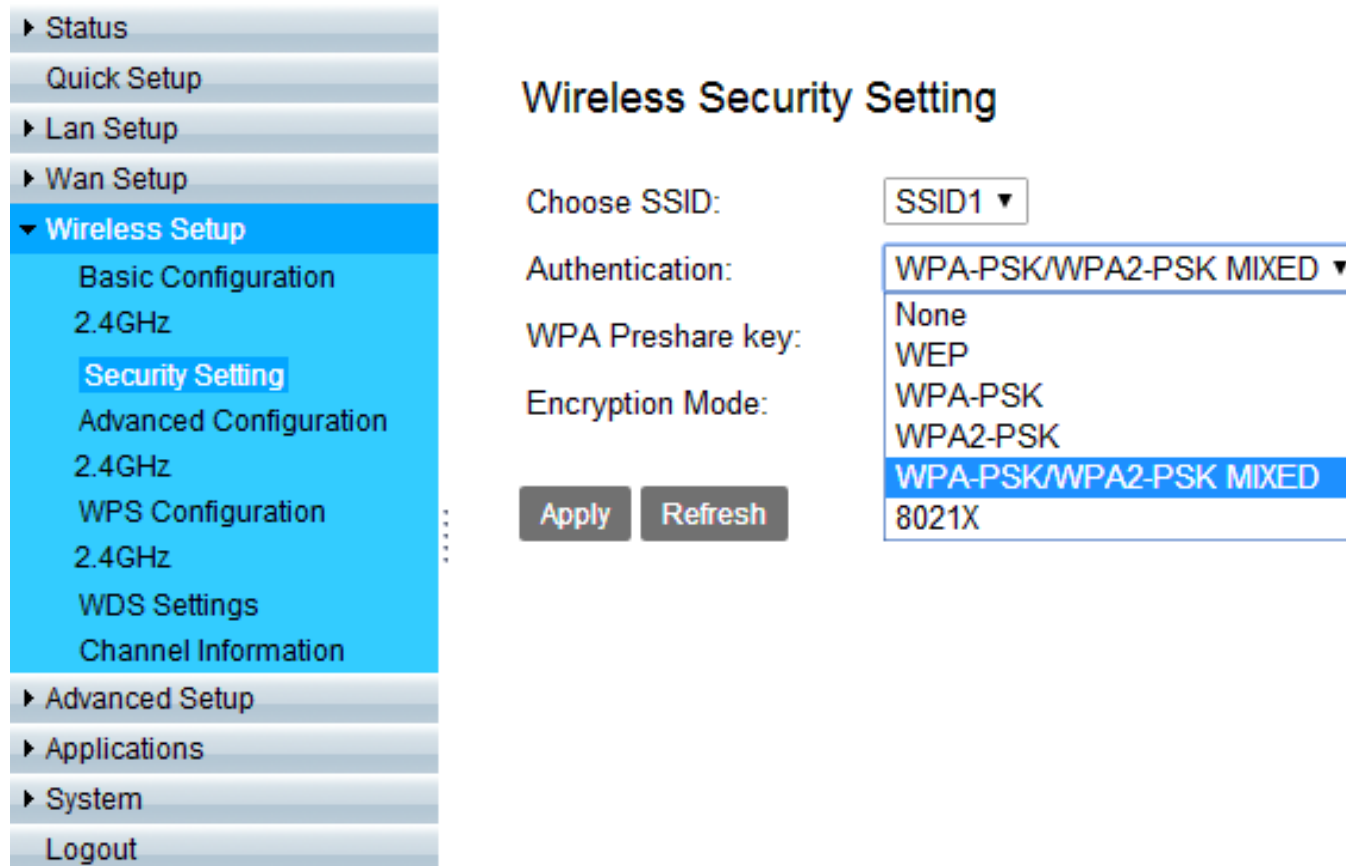

**Figure 4.5.2.2 Authentication Options**

## 4.6 Applications

### 4.6.1 IGMP Settings

Select “Multicast” → “IGMP” link in the left navigation bar. According to the WAN setting, if you want to test IGMP function on Router mode, you only need to enable IGMP function basic on the WAN Setup.

**IGMP Settings**

Enter IGMP protocol configuration fields if you want modify default vaules shown below.  
NOTE: Query Interval is advised to no longer than 125s.

Default Version:

Query Interval(s):

Query Response Interval(1/10s):

Last Member Query Interval(1/10s):

Robustness Value:

Maxinum Multicast Data Source(for IGMPv3):

Fast Leave Enable:

Membership Join Immediate(IPTV):

Enable IGMP Snooping:

Enable IGMP Proxy:

WAN Connection	Enable IGMP
vdsl	<input checked="" type="checkbox"/>

**Figure 4.6.1 IGMP Settings**

## 4.6.2 USB setup

Insert a U disk into the USB interface, then login 192.168.1.1, select " Storage Service"->"Storage Device Info" link in the left navigation bar. Confirm the system has mounted the U disk.

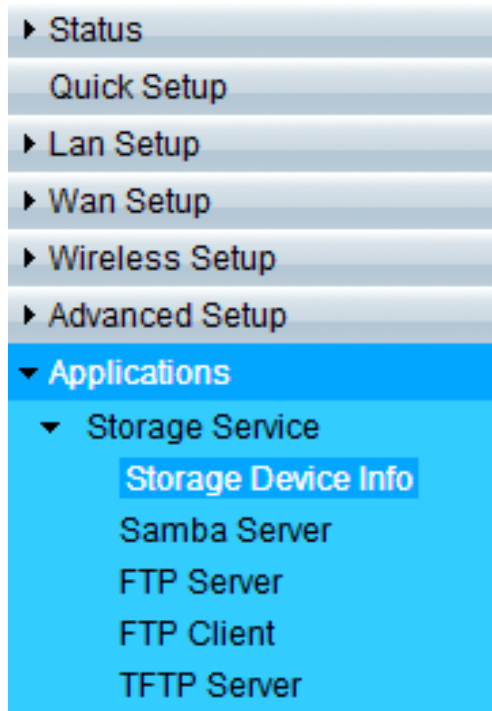

### Storage Device Info

Number	Provider	Product Type	Capacity(MB)
1	FUJITSU	MHV2040AH	39999

**Figure 4.6.2 USB Setup**

### 4.6.3 FTP Server

Select “Storage Device Info” → “FTP Server” link in the left navigation bar, on the right page you will see how to enable FTP Server function.

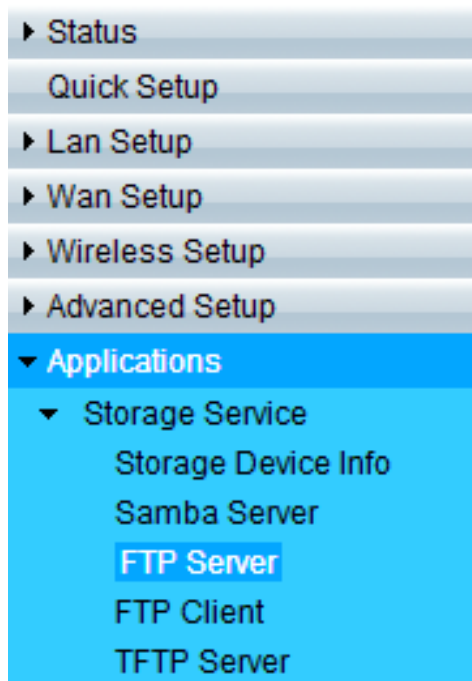

### Storage Service - FTP Service Setup

Note: To enable FTP Server, at least one storage device would be inserted.

Enable FTP Service:

FTP Directory:  ▼

Apply

Refresh

**Figure 4.6.3 FTP Service Setup**



### 4.6.4 FTP Client

Select “Storage Device Info” → “FTP Client” link in the left navigation bar, on the right page you can input FTP Client Settings, and click “Download”. Then, click “Refresh” to make sure the status is completed.

- ▶ Status
- Quick Setup
- ▶ Lan Setup
- ▶ Wan Setup
- ▶ Wireless Setup
- ▶ Advanced Setup
- ▼ Applications
  - ▼ Storage Service
    - Storage Device Info
    - Samba Server
    - FTP Server
    - FTP Client**
    - TFTP Server
    - Telnet Service
    - SSH Service
    - Printer Share
    - Multimedia Share
  - ▶ DNS
  - UPnP
  - ▶ Multicast
  - SNMP
  - ▶ VPN
- ▶ System
- Logout

#### Storage Service - FTP Client Settings

User Name:

Password:

Download URL:

Port:

Device:  ▼

Save Path:

**Download**

#### The latest 10 download records

**Refresh**

User Name	Password	Port	Download URL	Save Path	Progress	Status	Action
blake		21	ftp://netsys.com.tw/hello.htm	xdown	100%	complete	<b>Delete</b>

The latest 10 download records

**Refresh**

User Name	Password	Port	Download URL	Save Path	Progress	Status	Action
blake		21	ftp://netsys.com.tw/hello.htm	xdown	100%	complete	Delete

**Figure 4.6.4 FTP Client Settings**

### 4.6.5 TFTP Server

Select “Storage Device Info” → “TFTP Server” link in the left navigation bar, on the right page you will see how to enable TFTP Server function.

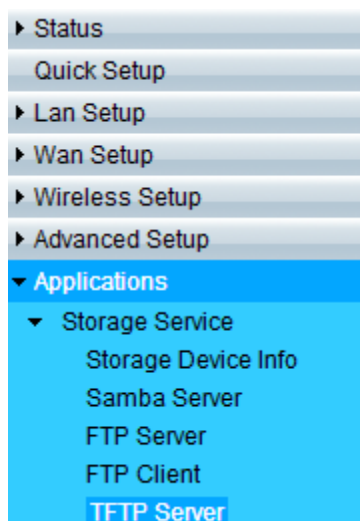

#### Storage Service - TFTP Service Setup

Note: To enable the TFTP Server, a storage device may be needed.

Enable TFTP Service:

TFTP Directory:

**Apply** **Refresh**

**Figure 4.6.5 TFTP Service Setup**

## 4.7 SNMP Setup

Click on “SNMP” link in the left navigation bar, on the right page you will see how to enable SNMP function. NV-720S supports SNMP V1/V2.

**SNMP Settings**

Enable SNMP	<input checked="" type="checkbox"/>
System Contact	net
System Name	net
System Location	net
Public community	public
Private community	private
Trap Enable	<input type="checkbox"/>
Trap Version	SNMP V1 ▾
Trap Address	192.168.1.100

**Apply** **Refresh**

**Figure 4.7 SNMP Settings**

Download “MG-SOFT MIB Browser”. below is picture for how to use the software.  
Connect Remote SNMP agent.

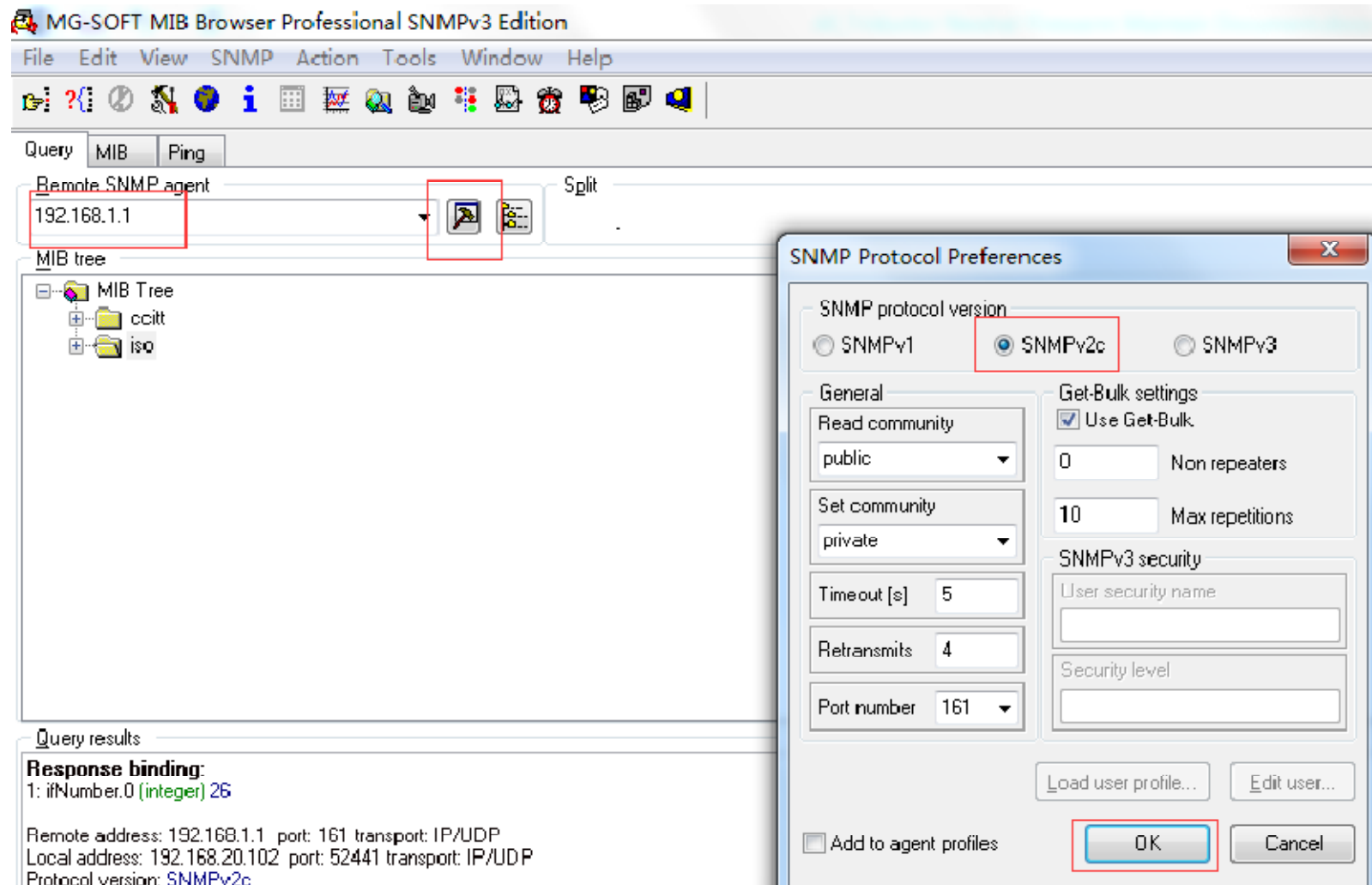

Select OID:1.3.6.1.2.1.1.3  
System Up Time

The screenshot shows a network management interface with the following sections:

- Query:** Includes tabs for 'MIB' and 'Ping'. A 'Remote SNMP agent' field contains the IP address '192.168.1.1'. There are icons for search and refresh, and a 'Split' checkbox.
- MIB tree:** A hierarchical tree structure showing the path to the 'sysUpTime' OID. The path is: MIB Tree > iso > org > dod > internet > mgmt > mib-2 > system > sysUpTime. The 'sysUpTime' node is highlighted with a red box.
- Query results:** Displays the output of an SNMP query. It shows the start and end of the query, the OID being queried, and the resulting value. The value '1: sysUpTimeInstance (timeticks) 0 days 16h:53m:09s.53h (6078953)' is highlighted with a red box.

```
***** SNMP QUERY STARTED *****
1: sysUpTimeInstance (timeticks) 0 days 16h:52m:37s.13h (6075713)
***** SNMP QUERY FINISHED *****

Remote address: 192.168.1.1 port: 161 transport: IP:UDP
Local address: 192.168.20.102 port: 64685 transport: IP:UDP
Protocol version: SNMPv2c
1: sysUpTimeInstance (timeticks) 0 days 16h:53m:09s.53h (6078953)
```

## Appendix A: Cable Requirements

### A.1 Ethernet Cable

A CAT 3~7 UTP (unshielded twisted pair) cable is typically used to connect the Ethernet device to the router. A 10Base-T cable often consists of four pairs of wires, two of which are used for transmission. The connector at the end of the 10Base-T cable is referred to as an RJ-45 connector and it consists of eight pins. The Ethernet standard uses pins 1, 2, 3 and 6 for data transmission purposes. (Table A-1)

**Table A-1** RJ-45 Ethernet Connector Pin Assignments

PIN #	MDI		MDI-X	
	Signal	Media Dependent interface	Signal	Media Dependent interface-cross
1	TX+	Transmit Data +	RX+	Receive Data +
2	TX-	Transmit Data -	RX-	Receive Data -
3	RX+	Receive Data +	TX+	Transmit Data +
4	--	Unused	--	Unused
5	--	Unused	--	Unused
6	RX-	Receive Data -	TX-	Transmit Data -
7	--	Unused	--	Unused
8	--	Unused	--	Unused

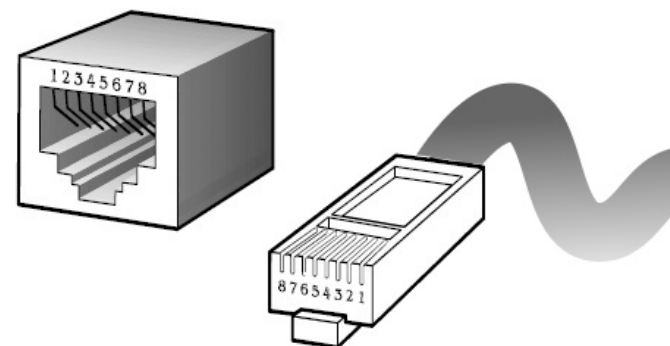

**Figure A-1** Standard RJ-45 receptacle/connector

**Note:**

Please make sure your connected cables have the same pin assignment as the table above before deploying the cables into your network.

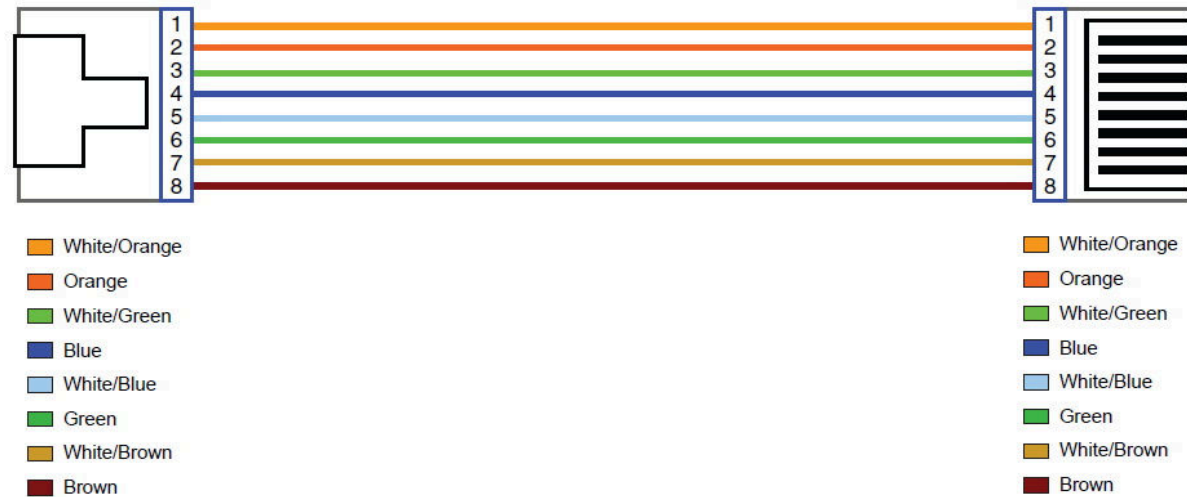

**Figure A-2 Pin Assignments and Wiring for an RJ-45 Straight-Through Cable**

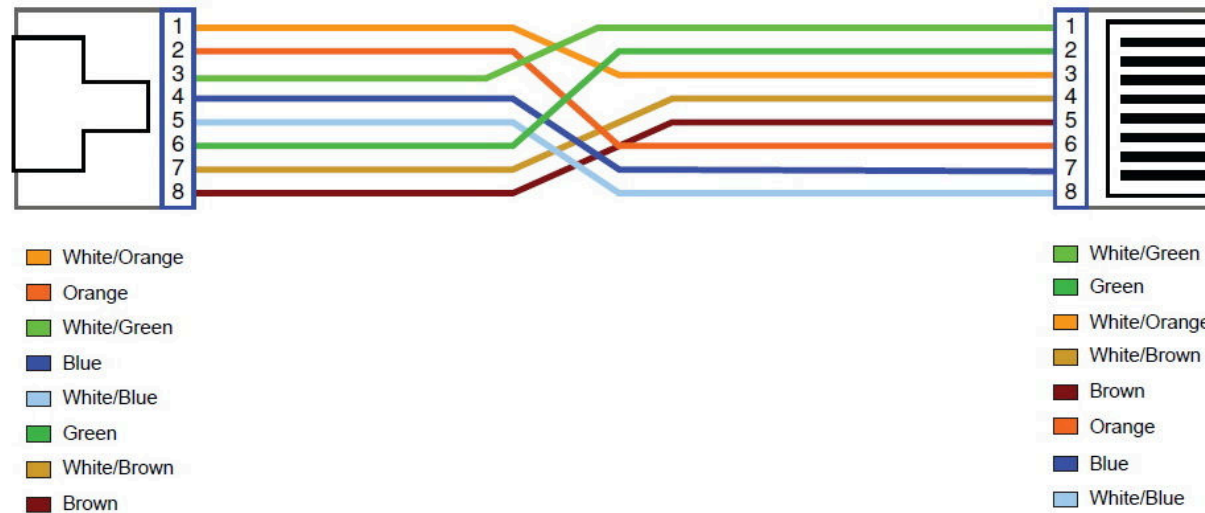

**Figure A-3 Pin Assignments and Wiring for an RJ-45 Crossover Cable**

**A.2 Telephone wire**

Standard telephone wire of any gauge or type-flat, twisted or quad is used to connect the Modem to the telephone network. A telephone cable typically consists of three pairs of wires, one of which is used for transmission. The connector at the end of the telephone cable is called an RJ-11 connector and it consists of six pins. POTS (plain old telephone services) use pins 3 and 4 for voice transmission. A telephone cable is shown below. (Figure A-6)

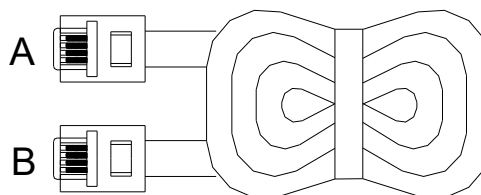

**Figure A-4 Telephone cable**

The A and B connectors on the rear of the Modem are RJ-11 connectors. These connectors are wired identically. The RJ-11 connectors have six positions, two of which are wired. The Modem uses the center two pins. The pin out assignment for these connectors is presented below. (Table A-3)

**Table A-3 RJ-11 Pin out Assignments**

Pin#	MNEMONIC	FUNCTION
1	NC	Unused
2	NC	Unused
3	TIP	POTS
4	RING	POTS
5	NC	Unused
6	NC	Unused



## **Appendix B: Product Specification**

### **Key Features & Benefits**

- ◆ Adopts ARM Cortex A9 dual-core processor
- ◆ Supports G.993.5 Vectoring and ADSL2+
- ◆ Supports G.998.4 G.INP
- ◆ Supports Dying Gasp
- ◆ Supports ATM and PTM transmission mode auto detection (ADSL backward compatible)
- ◆ Supports 8a, 8b, 8c, 8d, 12a, 12b, 17a, 17b, and 30a band profile and auto follow-up on CO side
- ◆ Supports 997, 998 band plan
- ◆ Supports ATM-TC, ATM and AAL5 (ATM Flow Throughput / OAM Cell Filter and Forwarding / AAL5 SAR:PVC / ATM Traffic Class / ATM PVC Shaping / ATM PVC Scheduling)
- ◆ Supports ATM Qos CBR, rt-VBR, nrt-VBR, UBR
- ◆ Support 2.4G single band wireless
- ◆ Compliant with IEEE 802.11b/g/n wireless standard with 2T2R MIMO (Up to 300 Mbps)
- ◆ Supports WPS, WMM, WDS
- ◆ Supports WEP, WPA, WPA2
- ◆ Supports QoS- IP version, LAN port, MAC, VLAN, 802.1P, IP address, DSCP, Protocol type
- ◆ Low power with Advanced Power Management
- ◆ Supports uPnP/PPPoE/PPPoATM/IPv4/IPv6/NAT/NAPT
- ◆ Supports static routing for IPv4 and IPv6 forwarding
- ◆ Supports Firewall functions contains Packet filtering, DMZ, Mac Address based filtering, Parental Control, Application based filtering

- ◆ Supports DHCP Server/ DHCP Relay/ DHCP Client/ DHCPv6 Client/ DHCPv6 Server/ DNS/ DNS Proxy or Relay/ DNSv6 Proxy or Relay/ NTP Client/HTTP1.1 server
- ◆ Supports Multicast IP table/IGMP v3 Proxy and Snooping
- ◆ Supports IEEE802.1q Tag VLAN
- ◆ Support IEEE 802.1p VLAN Priority and mapping to DSCP
- ◆ Support 8 queue MFC/DSCP both type QoS
- ◆ Supports HTTP/HTTPS web management
- ◆ Support SSL / SSH security
- ◆ Supports remote management and monitor
- ◆ Supports configuration backup and restore
- ◆ Provides surge protection for Line port
- ◆ Supports Router & Switch(Bridged) mode selection
- ◆ Supports Dual Firmware Image Backup
- ◆ Supports SNMP v1/v2
- ◆ Supports TR-069
- ◆ Supports VPN

**Notes:**

1. Features and specifications in this manual are subject to change without prior notice.
2. (\*) Firmware upgradeable for future enhancement.

## Product Specification

<b>Standards:</b>	IEEE802.3/802.3u/802.11b/802.11g/802.11n standards ITU-T G992.1/G992.3/G992.5/G993.1/G993.2/G993.5/G997.1/G998.4 standards
<b>Regulatory Compliance:</b>	FCC CE RoHS compliance
<b>Physical Interface:</b>	4 x RJ-45 10/100Mbps auto-negotiation Ethernet port 1 x RJ-11 for VDSL2 line port 2 x 2dBi external Antennas 1 x WPS Button 1 x Reset Button for resetting to factory default 1 x USB2.0 for connecting USB dongle
<b>LED Indicators:</b>	1 x Power LED 4 x Link/Active Status for Ethernet port 1 x Link LED for VDSL2 port 1 x WPS LED 1 x WLAN LED 1 x USB LED
<b>Wireless Frequency Range</b>	2.4GHz Single band
<b>Switch method:</b>	Store and forward

<b>Flow control:</b>	Full duplex: IEEE 802.3x Half duplex: Back pressure
<b>Typical Power Consumption:</b>	3.6 W(Full load)
<b>Power Supply:</b>	Input Voltage: 12 VDC/1A (Commercial-grade power adapter)
<b>Operating Temperature:</b>	0°C ~ 50°C (32°F ~ 122°F) Fan-less, free air cooling
<b>Storage Temperature:</b>	-20°C ~ 70°C (-4°F ~158°F)
<b>Humidity:</b>	10% to 90% (non-condensing)
<b>Dimensions:</b>	184 x 177 x 104 mm ( 7.2" x 6.9" x 4.1") with 2dBi Antenna
<b>Weight:</b>	0.44 Kg
<b>EMC:</b>	EMI Compliant: FCC EMS Compliant: CE mark

## Appendix C: Router/Bridged Mode select

This appendix describes how to select the router/bridged mode, The NV-720S default mode is router mode, please refer to the following steps to select the router mode or switch mode.

### ◆ Selecting the Router mode:

1. For configuring the router mode settings, click the **IPv4 Configuration** link (**LAN Setup**) on the left navigation bar. Select “Server” as the DHCP Mode and click **Apply** at any time during configuration to save the information that you have entered. A screen is displayed as shown in [Figure C.1](#)

**IPv4 Configuration**

IP Address:

Subnet Mask:

Primary DNS Server:

Secondary DNS Server:

Domain Name:

Disable DHCP
  Enable DHCP Relay
  Enable DHCP Server

Relay IP:

Start(PC):

End(PC):

Lease Time:  (Seconds)

**Figure C-1 DHCP Server**

2. Click the **WAN Service** link (**WAN Setup**) on the left navigation bar to specify the WAN Setup. Please Select as the DHCP Mode.

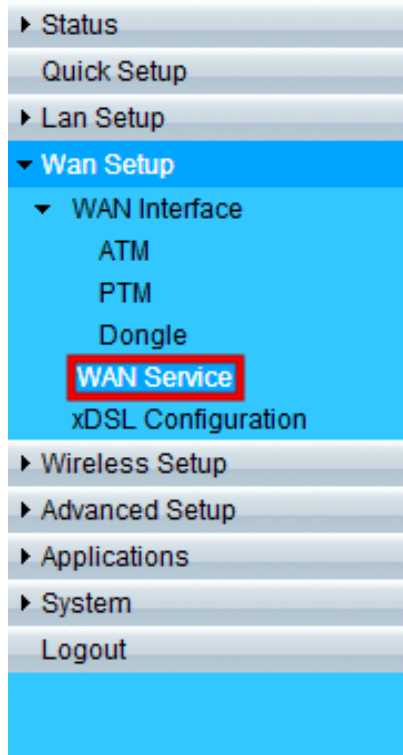

### WAN ServiceInfo

WAN Name	Interface	Mode	IP Protocol Type	Service Type	Edit/Delete	
vdsI_PPpOE	PTM	PPPoE	IPv4	TR069_INTERNET	Edit	Delete

### Set New WAN

Interface:

Mode:

- DHCP
- DHCP
- Static
- PPPoE
- Bridge

**Figure C-2 WAN Setup**

3. Please refer to the **section 4.2** for configuring the WAN type; the user can configure the Dynamic IP Address, Static IP Address,

PPPoE mode.

**WAN Service**

Connection Name:

Enable:

MTU:

IP Protocol Type:

NAT:

IPv4 Static DNS:

PPPoE Type:

Servicename:

User Name:

Password:

Authentication Type:

Dial Mode:

Keep Alive Time:  (10-30)s

Keep Alive Max Fail:  (1-100)

MAC Address Override:

Enable VLAN:

Service Type:

**Advanced Settings**

**Figure C-3 Configuring WAN Type**

- ◆ Click **Apply** for applying the changes.
- ◆ Click **Back** to exit from this page without saving the changes.

◆ **Select the Bridged mode:**

1. To configure the bridged mode settings, click the **IPv4 Configuration** link (**LAN Setup**) on the left navigation bar. And click Apply at any time during configuration to save the information that you have entered. A screen is displayed as shown in [Figure C.4](#)

**IPv4 Configuration**

IP Address: 192.168.16.234

Subnet Mask: 255.255.255.0

Primary DNS Server: 192.168.16.234

Secondary DNS Server:

Domain Name: localhost

Disable DHCP  Enable DHCP Relay  Enable DHCP Server

Relay IP: 192.168.16.1

Start(PC): 192.168.1.2

End(PC): 192.168.1.254

Lease Time: 86400 (Seconds)

Edit Reserved IP Address

Edit Dhcp Option 60 Edit Dhcp Options

Apply Refresh

**Figure C-4 DHCP Mode – Disable**



2. Click the **WAN Service** link (**WAN Setup**) on the left navigation bar to specify the WAN setup. A screen is displayed as shown in Figure C.5

**WAN Service Info**

WAN Name	Interface	Mode	IP Protocol Type	Service Type	Edit/Delete
----------	-----------	------	------------------	--------------	-------------

**Set New WAN**

Interface:

Mode:

- ▶ Status
- Quick Setup
- ▶ Lan Setup
- ▼ Wan Setup
  - ▶ WAN Interface
    - WAN Service**
    - xDSL Configuration
- ▶ Wireless Setup
- ▶ Advanced Setup
- ▶ Applications
- ▶ System
- Logout

## WAN Service

Connection Name:

Enable:

IP Protocol Type:

Enable VLAN:

Service Type:

### Advanced Settings

Static Route Setting

Connection Name:	LAN ▾
Enable:	<input checked="" type="checkbox"/>
Destination Subnet:	0.0.0.0
Subnet Mask:	0.0.0.0
Gateway:	192.168.16.1
Metrics:	1

Back Apply Refresh

**Figure C-5 WAN Setting**

## **Appendix D: Troubleshooting**

### **Diagnosing the Router's Indicators**

The router can be easily monitored through its comprehensive panel indicators. These indicators assist the network manager in identifying problems the hub may encounter. This section describes common problems you may encounter and possible solutions.

<b>1. Symptom:</b>	POWER indicator does not light up (green) after power on.
<b>Cause:</b>	Defective External power supply
<b>Solution:</b>	Check the power plug by plugging in another that is functioning properly. Check the power cord with another device. Check the terminal block make sure to fasten the power cord. If these measures fail to resolve the problem, have the unit power supply replaced by a qualified distributor.
<b>Note:</b>	Please refer to the power status table to check power input status. Section 3.3
<b>2. Symptom:</b>	Link indicator does not light up (green) after making a connection.
<b>Cause:</b>	Network interface (ex. a network adapter card on the attached device), network cable, or switch port is defective.
<b>Solution:</b>	<ol style="list-style-type: none"> <li>2.1 Power off and re-power on the VDSL2 router.</li> <li>2.2 Verify that the switch and attached device are power on.</li> <li>2.3 Be sure the cable is plugged into both the switch and corresponding device.</li> <li>2.4 Verify that the proper cable type is used and its length does not exceed specified limits.</li> <li>2.5 Check the router on the attached device and cable connections for possible defects.</li> <li>2.6 Make sure that the phone wire must be connecting NV-720S first, when powered on.</li> <li>2.7 Replace the defective router or cable if necessary.</li> </ol>

<b>3. Symptom:</b>	VDSL Link cannot be established.
<b>Cause:</b>	VDSL setting failure or phone cable length is over the specification limit.
<b>Solution:</b>	<p>3.1 Please make sure that the phone wire must be connected between CO side and NV-720S (CPE) when both are power on. CO side will do link speed function depending on phone wire length, therefore if CO side can't detect NV-720S (CPE) over phone wire while both power on, this will cause the link to fail.</p> <p>3.2 Please check the phone wire, we recommend using 24-26 gauge twisted pair cables without rust.</p> <p>3.3 Please reinsert power when changing the cable length or link time over 3 minutes.</p>
<b>Note:</b>	The phone wire must meet CAT 3 standard or above and <b>without clustering</b> , otherwise it will cause more cross talk, reducing the DSL power driver.
<b>4. Question:</b>	What is VDSL2? (Only reference)
<b>Answer:</b>	<p>Very-high-speed digital subscriber line 2 (VDSL2) is an access technology that exploits the existing infrastructure of copper wires that were originally deployed for traditional telephone service. It can be deployed from central offices, from fiber-optic connected cabinets located near the customer premises, or within buildings. It was defined in standard ITU-T G.993.2 finalized in 2005.</p> <p>VDSL2 was the newest and most advanced standard of digital subscriber line (DSL) broadband wire line communications. Designed to support the wide deployment of triple play services such as voice, video, data, high definition television (HDTV) and interactive gaming, VDSL2 was intended to enable operators and carriers to gradually, flexibly, and cost-efficiently upgrade existing xDSL infrastructure.</p>

The protocol was standardized in the International Telecommunication Union telecommunications sector (ITU-T) as Recommendation G.993.2. It was announced as finalized on 27 May 2005, [1] and first published on 17 February 2006. Several corrections and amendments were published in 2007 through 2011.

VDSL2 is an enhancement to very-high-bit rate digital subscriber line (VDSL), Recommendation G.993.1. It permits the transmission of asymmetric and symmetric aggregate data rates up to 200 Mbit/s downstream and upstream on twisted pairs using a bandwidth up to 30 MHz.

VDSL2 deteriorates quickly from a theoretical maximum of 250 Mbit/s at source to 100 Mbit/s at 0.5 km (1,600 ft.) and 50 Mbit/s at 1 km (3,300 ft.), but degrades at a much slower rate from there, and still outperforms VDSL. Starting from 1.6 km (1 mi) its performance is equal to ADSL2+.

ADSL-like long reach performance is one of the key advantages of VDSL2. LR-VDSL2 enabled systems are capable of supporting speeds of around 1–4 Mbit/s (downstream) over distances of 4–5 km (2.5–3 miles), gradually increasing the bit rate up to symmetric 100 Mbit/s as loop-length shortens. This means that VDSL2-based systems, unlike VDSL1 systems, are not limited to short local loops or MTU/MDUs only, but can also be used for medium range applications.

<b>5. Question:</b>	What is SNR (Signal-to-Noise)? (Only reference)
<b>Answer:</b>	Signal-to-noise ratio (often abbreviated SNR or S/N) is a measure used in science and engineering that compares the level of a desired signal to the level of background noise. It is defined as the ratio of signal power to the noise power. A ratio higher than 1:1 indicates more signal than noise. While

	<p>SNR is commonly quoted for electrical signals, it can be applied to any form of signal (such as isotope levels in an ice core or biochemical signaling between cells). The ratio is usually measured in decibels(dB)</p> <p>The signal-to-noise ratio, the bandwidth, and the channel capacity of a communication channel are connected by the Shannon–Hartley theorem.</p> <p>In digital communications, the SNR will probably cause a reduction in data speed because of frequent errors that require the source (transmitting) computer or terminal to resend some packets of data. SNR measures the quality of a transmission channel over a network channel. The greater the ratio, the easier it is to identify and subsequently isolate and eliminate the source of noise.</p>
--	--

<b>6. Symptom:</b>	Connected the CO Router with CPE Router within 300 meters RJ-11 phone cable got only less than 10 Mbit/s.
<b>Cause:</b>	Some testing programs which are based on TCP/IP protocols such as FTP, Iperf, NetIQ, the testing bandwidth outcome will be limited by TCP window size.
<b>Solution:</b>	We recommend testing VDSL2 bandwidth using Smartbits® equipment or IPERF program. The TCP window size must be set to max. 64k, the parameter as iperf -c server IP address -i 1 -t 50 -w 65535 for client side.

<b>7. Question:</b>	I just bought a Netsys NV-720S to replace my Quest DSL modem for my home. I was told any VDSL2 modem would work and give me higher communication speeds. It doesn't get me internet when hooked up. All lights come on but no Link light. Is this the complete wrong application for this unit?
<b>Answer:</b>	Please note NV-720S is a remote side (CPE side), it must be connected to the CO side to work. Tone mode, Band profile and band plan settings must be compatible with each other, if not; access

	error will show when applied. Please deactivate and activate once the settings have been changed.
--	---

<b>8. Question:</b>	We need to set up a default gateway on a NV-720 pair which is in Bridge mode, as they want to manage the units from a different network.
---------------------	--

<b>Answer:</b>	<p>When the application is used within the LAN, the switch (bridged) mode is not necessary to set up a gateway .However, if the application crosses various network segments (LAN to WAN or WAN to LAN), you must set up a gateway to connect a different network segment.</p> <p>Regarding on how to configure a default gateway at switch (bridged) mode for crossing various network segments.</p> <p>Example for configuring the gateway from static routing:</p> <p>Destination LAN IP: 0-0-0-0</p> <p>Subnet Mask: 0-0-0-0</p> <p>Gateway: 255-255-255-0</p> <p><b>Note:</b> Static Routing functionality is used to define the connected Gateway between the LAN and WAN.</p>
----------------	--

<b>9. Question:</b>	What can I do if I forgot my password?
---------------------	--

<b>Answer:</b>	<p>If you forgot your password, you must reset your router. This process will change all your settings back to the factory default. To reset the router, locate the reset button on the rear panel of the unit.</p> <p>With the router powered on, use a paperclip to hold the button down for over 5 seconds. Release the button and the router will go through its reboot process. The default IP is 192.168.1.1. When logging in, the default username and password are both <b>“admin”</b>.</p>
----------------	---



<b>10. Question:</b>	Is it possible to use ADSL2 IP DSLAM with the NV-720S?
<b>Answer:</b>	NV-720S support the ADSL Annex B backward compatible, therefore the NV-720S can connect to ADSL2 IP DSLAM.
<b>11. Question:</b>	I have purchased a kit of NV-802S and NV-720S to extend the property Wi-Fi network. They will sit in the property LAN which is served by a modem router and off an ADSL telecom connection. Each NV unit will have a fixed IP LAN address. All Wi-Fi user addresses are provided by the gateway modem router. The reason for purchase is to extend the LAN service via phone lines to the Wi-Fi access point. I would appreciate a simple configure set up for each unit. e.g. should the NV-802S be configured as a switch or router?. Do I need to configure a VDSL2 WAN between the NV-802S and NV-720S?
<b>Answer:</b>	Basically, use default settings that the network can be established. NV-802S should configure to switch mode (default mode), and NV-720S configure to router mode (default mode).
<b>12. Question:</b>	What is the maximum Ethernet frame MTU for these routers?
<b>Answer:</b>	NV-720S maximum Ethernet frame MTU is 2000 bytes.
<b>13. Question:</b>	We have a customer who previously had the NV-720S (regular antenna) and we sent them a NV-720S with the 5db antenna (high power output) to replace the original unit when it failed, but the new unit with 5db antenna has less coverage than the original unit. Can you please send me the NV-720S wireless configuration settings to optimize the range of the high output antenna? If they are the same, why is the NV-720S with the 5db antenna, providing less coverage? Please advise.
<b>Answer:</b>	Please note that the two antennas have almost the same coverage range, the difference between the

two antennas is the Gain pattern shape (the 5dBi Gain pattern shape is butterfly and the 2dBi Gain pattern shape is chubbier), and also the 5dBi antenna has higher penetrating power (ex. Through walls).  
 So regarding this issue, we don't think that the 5dBi is providing less coverage, we think is because of the Gain pattern shape. Furthermore, the actual performance will vary depending on the environment factors.

**Gain Pattern 2dBi Antenna**

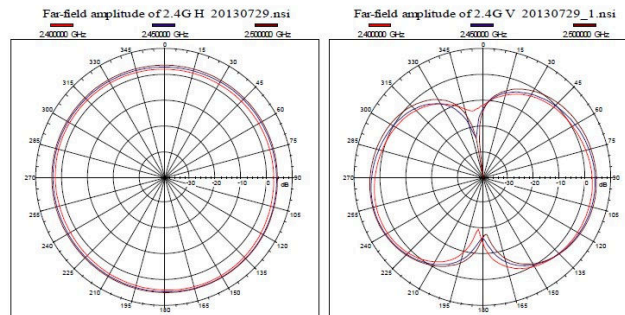

**Gain Pattern 5dBi Antenna**

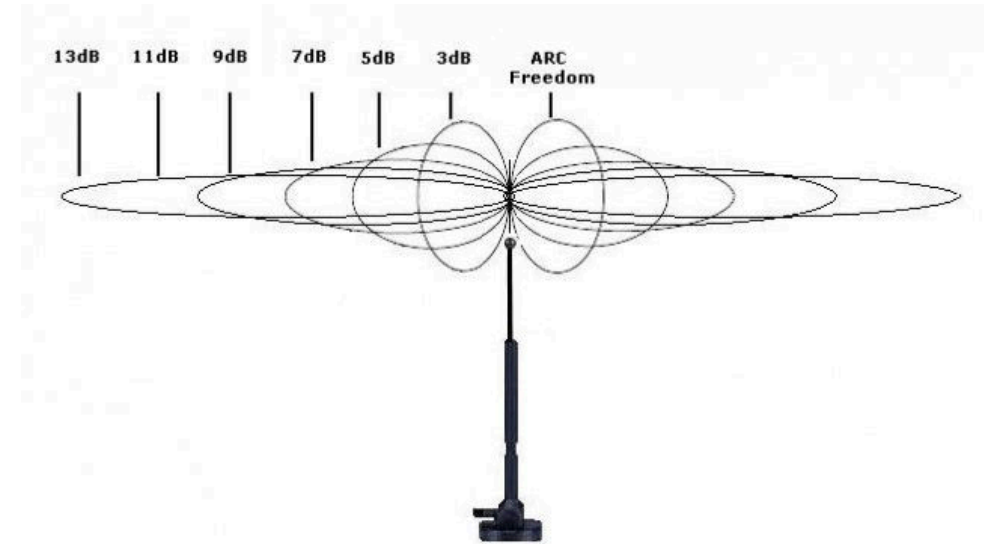
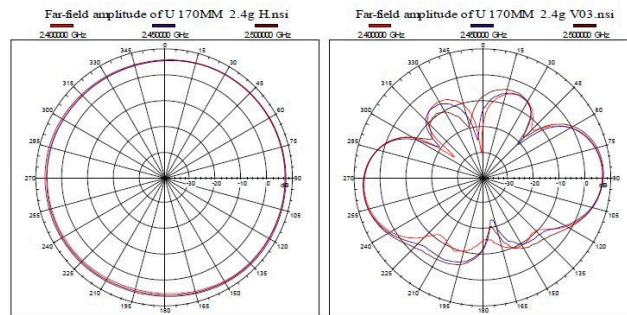

## System Diagnostics

### Power and Cooling

If the POWER indicator does not turn on when the power cord is plugged in, you may have a problem with the power outlet, power cord, or internal power supply as explained in the previous section. However, if the unit power is off after running for a while, check for loose power connections, power losses or surges at the power outlet. If you still cannot isolate the problem, then the internal power supply may be defective. In this case, please contact your local dealer.

### Installation

Verify that all system components have been properly installed. If one or more components appear to be malfunctioning (e.g. the power cord or network cabling), test them in an alternate environment where you are sure that all the other components are functioning properly.

### Transmission Mode

The transmission mode for RJ45 ports is Giga Ethernet, for RJ-11 port is auto-negotiation VDSL2. Therefore, if the Link signal is disrupted (e.g. by unplugging the network cable and plugging it back in again, or by resetting the power), the port will try to reestablish communications with the attached device via auto-negotiation. If auto-negotiation fails, then communications are set to half duplex by default. Based on this type of commercial-standard connection policy, if you are using a full-duplex device that does not support auto-negotiation, communications can be easily lost (i.e. reset to the wrong mode) whenever the attached device is reset or experiences a power fluctuation, the best way to resolve this problem is to upgrade these devices to a version that support Ethernet and VDSL.

### **Physical Configuration**

If problems occur after altering the network configuration, restore the original connections, and try to track the problem down by implementing the new changes, one step at a time. Ensure that cable distances and other physical aspects of the installation do not exceed recommendations.

### **System Integrity**

As a last resort verify the switch integrity with a power-on reset. Turn the power to the switch off and then on several times. If the problem still persists and you have completed all the preceding diagnoses, then contact your dealer.

## **Appendix E: Compliance Information**

### **FCC Radio Frequency Interference Statement**

This equipment has been tested and found to comply with the limits for a computing device, pursuant to Part 15 of FCC rules. These limits are designed to provide reasonable protection against harmful interference when the equipment is operated in a commercial environment. This equipment generates uses and can radiate radio frequency energy and, if not installed and used in accordance with the instructions, may cause harmful interference to radio communications. However, there is no guarantee that interference will not occur in a particular installation. If this equipment does cause harmful interference to radio or television reception, which can be determined by turning the equipment off and on, the user is encouraged to try to correct the interference by one or more of the following measures:

1. Reorient or relocate the receiving antenna.
2. Increase the separation between the equipment and receiver.
3. The equipment and the receiver should be connected to outlets on separate circuits.
4. Consult the dealer or an experienced radio/television technician for help.

Changes or modifications not expressly approved by the party responsible for compliance could void the user's authority to operate the equipment.

If this telephone equipment causes harm to the telephone network, the telephone company will notify you in advance that temporary discontinuance of service may be required. But if advance notice isn't practical, the telephone company will notify the customer as soon as possible. Also, you will be advised of your right to file a complaint with the FCC if you believe it is necessary.

The telephone company may make changes in its facilities, equipment, operations or procedures that could affect the proper functioning of your equipment. If they do, you will be notified in advance in order for you to make necessary modifications to maintain uninterrupted service.

This equipment may not be used on coin service provided by the telephone company. Connection to party lines is subject to state tariffs.

**FCC Radiation Exposure Statement:**

This equipment complies with FCC radiation exposure limits set forth for an uncontrolled environment. This equipment should be installed and operated with minimum distance **20cm** between the radiator & your body.

**FCC Warning**



This equipment has been tested to comply with the limits for a **Class A** digital device, pursuant to Part 15 of the FCC Rules. These limits are designed to provide reasonable protection against harmful interference when the equipment is operated in a commercial environment. This equipment can generate, use, and radiate radio frequency energy and, if not installed and used in accordance with the instruction manual, may cause harmful interference to radio communications. Operation of this equipment in a residential area is likely to cause harmful interference in which case the user will be required to correct the interference at owner's expense.

**FCC ID: 2AOKZNV720XX**

This device complies with part 15 of the FCC rules. Operation is subject to the follow Two Conditions.

(1)This device may not cause harmful interference and

(2)This device must accept any interference including interference that may cause undesired operation.

**CE Mark Warning**



**This is a class A product.** In a domestic environment, this product may cause radio interference in which case the user may be required to take adequate measures.

### RoHS Warning



RoHS stands for Restriction of Hazardous Substances, and impacts the entire electronics industry and many electrical products as well. The original RoHS, also known as Directive 2002/95/EC, originated in the European Union in 2002 and restricts the use of six hazardous materials found in electrical and electronic products. All applicable products in the EU market since July 1, 2006 must pass RoHS compliance. Directive 2011/65/EU was published in 2011 by the EU, which is known as RoHS-Recast or RoHS 2. RoHS 2 includes a **CE-marking directive**, with RoHS compliance now being required for CE marking of products. RoHS 2 also added Categories 8 and 9, and has additional compliance recordkeeping requirements. Directive 2015/863 was published in 2015 by the EU, which is known as RoHS 3. RoHS 3 adds four additional restricted substances (phthalates) to the list of six.

### WEEE Warning



To avoid the potential effects on the environment and human health as a result of the presence of hazardous substances in electrical and electronic equipment, end users of electrical and electronic equipment should understand the meaning of the crossed-out wheeled bin symbol. Do not dispose of WEEE as unsorted municipal waste and have to collect such WEEE separately.



### Warranty

The original product that the owner delivered in this package will be free from defects in material and workmanship for one year parts after purchase.

There will be a minimal charge to replace consumable components, such as fuses, power transformers, and mechanical cooling devices. The warranty will not apply to any products which have been subjected to any misuse, neglect or accidental damage, or which contain defects which are in any way attributable to improper installation or to alteration or repairs made or performed by any person not under control of the original owner.

The above warranty is in lieu of any other warranty, whether express, implied, or statutory, including but not limited to any warranty of merchantability, fitness for a particular purpose or any warranty arising out of any proposal, specification or sample. We shall not be liable for incidental or consequential damages. We neither assume nor authorize any person to assume for it any other liability.

**WARNING**  
Warranty Void  
If Removed

### **WARNING:**

- 1. DO NOT TEAR OFF OR REMOVE THE WARRANTY STICKER AS SHOWN, OR THE WARRANTY IS VOID.**
- 2. WARRANTY VOID IF USE COMMERCIAL-GRADE POWER ADAPTER IS USED AT HARSH ENVIRONMENTS.**

**Chinese SJ/T 11364-2014**

部件名称	有毒有害物质或元素					
	铅(Pb)	汞(Hg)	镉(Cd)	六价铬[Cr(VI)]	多溴联苯(PBB)	多溴二苯醚(PBDE)
结构壳体	○	○	○	○	○	○
电路组	○	○	○	○	○	○
包装及配件	○	○	○	○	○	○
○：表示该有毒物质在该部件所有均质材料中的含量均在 SJ/T 11364/2014 标准规定的限量要求以下。 ×：表示该有毒物质至少在该部件的某依均质材料中的含量超出 SJ/T 11364-2014 标准规定的限量要求。						

上述规范仅适用于中国法律